



<http://www.ebaman.com>

DC Power Supply
DPR Series
Model 6255A



**DC POWER SUPPLY
DPR SERIES
MODEL 6255A**

**OPERATING AND SERVICE MANUAL
FOR SERIAL NUMBERS 7F0651 - 7F0850***

***For Serial Numbers Above 7F0850
Check for inclusion of
Change Page.**

100 Locust Avenue, Berkeley Heights, New Jersey 07922

TABLE OF CONTENTS

Section	Page No.	Section	Page No.
I GENERAL INFORMATION.....	1-1	IV PRINCIPLES OF OPERATION.....	4-1
1-1 Description	1-1	4-1 Overall Block Diagram	
1-6 Specifications	1-1	Discussion	4-1
1-8 Options	1-1	4-5 Simplified Schematic	4-2
1-10 Instrument Identification	1-2	4-8 Detailed Circuit Analysis	4-3
1-13 Ordering Additional Manuals	1-2	4-9 Feedback Loop	4-3
II INSTALLATION	2-1	4-14 Series Regulator	4-3
2-1 Initial Inspection	2-1	4-16 Constant Voltage Input	
2-3 Mechanical Check	2-1	Circuit	4-3
2-5 Electrical Check	2-1	4-20 Constant Current Input	
2-7 Installation Data	2-1	Circuit	4-4
2-9 Location	2-1	4-25 Voltage Clamp Circuit	4-4
2-11 Rack Mounting	2-1	4-28 Mixer and Error Amplifiers	4-4
2-13 Input Power Requirements	2-1	4-31 Reference Circuit	4-4
2-15 Connections for		4-34 Meter Circuit	4-5
230 Volt Operation	2-1	V MAINTENANCE	5-1
2-17 Power Cable	2-2	5-1 Introduction	5-1
2-20 Repackaging for Shipment	2-2	5-3 General Measurement	
III OPERATING INSTRUCTIONS	3-1	Techniques	5-1
3-1 Operating Controls and		5-8 Test Equipment Required	5-1
Indicators	3-1	5-10 Performance Test	5-3
3-3 Operating Modes	3-1	5-12 Constant Voltage Tests	5-3
3-5 Normal Operating Mode	3-1	5-34 Constant Current Tests	5-7
3-7 Constant Voltage	3-1	5-39 Troubleshooting	5-9
3-9 Constant Current	3-1	5-41 Trouble Analysis	5-9
3-11 Connecting Load	3-2	5-46 Repair and Replacement	5-14
3-14 Operation of Supply Beyond		5-48 Adjustment and Calibration	5-15
Rated Output	3-2	5-50 Meter Zero	5-15
3-16 Optional Operating Modes	3-2	5-52 Voltmeter Tracking	5-16
3-17 Remote Programming,		5-54 Ammeter Tracking	5-16
Constant Voltage	3-2	5-56 Constant Voltage Programming	
3-24 Remote Programming,		Current	5-16
Constant Current	3-3	5-59 Constant Current Programming	
3-30 Remote Sensing	3-3	Current	5-16
3-35 Series Operation	3-4	5-62 Reference Circuit Adjustments	5-17
3-39 Parallel Operation	3-5	5-64 Constant Voltage Transient	
3-42 Auto-Tracking Operation	3-6	Response	5-17
3-45 Special Operating		VI REPLACEABLE PARTS	6-1
Considerations	3-6	6-1 Introduction	6-1
3-46 Pulse Loading	3-6	6-4 Ordering Information	6-1
3-48 Output Capacitance	3-6	APPENDIX A	A-1
3-51 Reverse Voltage Loading	3-7		
3-53 Reverse Current Loading	3-7		

MANUAL CHANGES
 Model 6255A DC Power Supply
 Manual HP P/N 06255-90002

7/5/88

Make all corrections in the manual according to errata below, then check the following table for your power supply serial number and enter any listed changes(s) in the manual.

SERIAL		MAKE CHANGES
Prefix	Number	
ALL		ERRATA
7F	00851-00950	1
7L	00951-01275	1,2
7L	01276-01500	1,2,3
7L	01501-01560	1,2,3,4
8L	01561-02310	1-5
8L	02311-02400	1-6
8L	02401-02460	1-7
1145A	02461-02965	1-8
1145A	02966-03595	1-9
1145A	03596-04575	1-10
1914A	04576-04655	1-11
1924A	04656-04995	1-12
2012A	04996-06555	1-13
2312A	06556-06675	1-14
2324A	06676-06795	1-15
2342A	06796-07035	1-16
2410A	07036-08305	1-17
2625A	08306-up	1-18

CHANGE 1:

In the replaceable parts table, make the following changes: R15: Change to 240 k ohm, 1/2 W, HP P/N 0686-2445. R35: Change to 120 ohm, 1/2 W, HP P/N 0686-1215. R40: Delete resistor R40. R62: Change to 750 ohm, 1/8 W, HP P/N 0757-0420. R63: Change to potentiometer, 5 k ohm, HP P/N 2100-1824. R64,65: Change to 12 k ohm, 1/8 W, HP P/N 0698-5088. VR6: Add new Zener diode, VR6 (4.22 V) HP P/N 1902-3070.

On the schematic, delete resistor R40 in the meter circuit and connect VR6 in its place. Anode of VR6 to base of Q15 and cathode to +12 V.

CHANGE 2:

On the Title Page, change Serial Number Prefix from "7F" to "7L."

In the replaceable parts table, delete switch/indicator S1/DS1 and add new "toggle" type switch and separate indicator as follows: S1: Switch, SPST, ON/OFF, HP P/N 3101-1055. DS1: Indicator lamp, neon, HP P/N 1450-0048.

CHANGE 3:

In the replaceable parts table on the schematic, add new resistor R78, 100 ohm, +/-5%, 1/2 W, HP P/N 0686-1015. Connect R78 between base of Q4 and emitter of Q5.

CHANGE 4:

In the replaceable parts table, change Q11 to 2N4045, HP P/N 1854-0221.

CHANGE 5:

On the title page, change Serial Number Prefix to "8L."

In the replaceable parts table, make the following changes: Add DS1, qty 1 (total qty 2), Pilot Light, Neon Sloan, HP P/N 1450-0048. Add F1, qty 1 (total qty 2), fuse cartridge, 2 Amp, HP P/N 2110-0002. Add R80, 33 k ohm, 1/2 W, +/-5%, qty 1 (total qty 2) HP P/N 0686-3335.

On the schematic, input power area, show separate fuse, pilot light, and resistor (R80) for the power transformer for each supply (A and B). Only the power-on switch (S1) and the line cord are now common to both supplies. Input power circuit now appears as shown at the top of the next page.

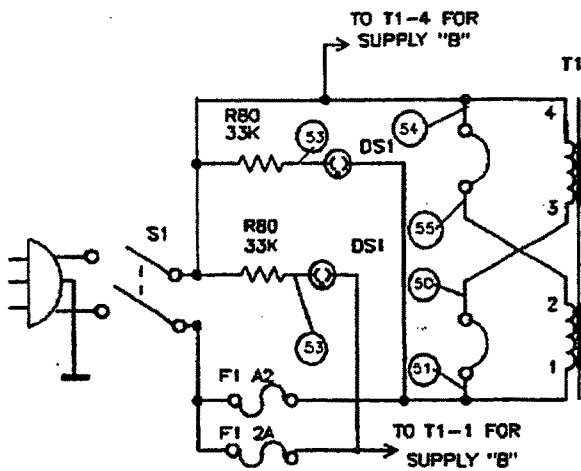

CHANGE 6:

In the replaceable parts table, change the HP P/N of switch S1 to 3101-1061.

CHANGE 7:

In the replaceable parts table and on the schematic, change Power Transformer T12 to HP P/N 5080-7185.

CHANGE 8:

The Serial Prefix of this unit has been changed to 1145A. This is the only change.

CHANGE 9:

In the replaceable parts list, delete the two transformer brackets: HP P/N 5000-6087 and 5000-6183; and add these three transformer brackets: HP P/N 5000-9398, 5000-9399, and 5000-6083 (one of each). In the Option 011 Appendix on page A-2, change HP P/N for CR4 from 1884-0031 to 1884-0032.

ERRATA:

In the replaceable parts list, change the HP P/N for C14 to 0180-1986. In the upper part of Figure 3-9, delete the strap shown between terminals (GND) and (+) on the terminal board of the slave supply.

In Table 1-1, change the INTERNAL IMPEDANCE AS A CONSTANT VOLTAGE SOURCE (Output Impedance specification to read): OUTPUT IMPEDANCE (TYPICAL): Approximated by a 10 milliohm resistance in series with a 1 microhenry inductance.

In the parts list and on the schematic, change R12 to 1.4 k, 5%, 3 W, 30ppm 0811-1804.

The standard colors for this instrument are now mint gray (for front panel) and olive gray (for all other external surfaces). Option X95 designates use of the former color scheme of light gray and blue gray. Option A85 designates use of a light gray front panel with olive gray used for all other external surfaces. New part numbers are shown on the last page of this change page.

Change the part number of pilot light DS1 to 1450-0566. This new light is more reliable than the former one.

CHANGE 10:

Add to paragraph 2-16 and to the parts list the correct fuse (F1) for Option 028 (230 Vac) instruments. For both sections of the sections of the supply, fuse F1 should be a 1A slow-blow type, HP P/N 2110-0007.

ERRATA:

Effective January 1st, 1977, Options 007 (10-turn voltage control) and 008 (10-turn current control) are no longer available individually, but they are still available combined as Option 009. Likewise, Options 013 (10-turn voltage control with decadal) and 014 (10-turn current control with decadal) are no longer available individually, but they are available combined into a single new option designated Option 015. Make these changes wherever Option 007, 008, 013, or 014 is mentioned in the manual.

CHANGE 13:

The blue-gray meter bezel has been replaced by a black one, HP P/N 4040-0414.

On page 6-7, change the HP P/N of Option 10 Slides to 1490-0872.

The front panel binding posts have been changed to a type with better designated insulation. Delete the two types of posts listed on page 6-7 of the parts list and: black binding post, HP P/N 1510-0114 (qty. 4); and red binding post, HP P/N 1510-0115 (qty. 2).

CHANGE 14:

In the replaceable parts list page 6-5, and on the Schematic, change C5 to .0022uF, 10%, 200 V, HP P/N 0160-0154, Qty. 1.

CHANGE 11:

On page 6-7, change HP P/N for front panel + and - binding posts to: 1510-0091, red, qty 4. Change HP P/N for front panel GND binding post to: 1510-0107, black, qty. 2. Add HP P/N for solder Lugs mounted behind GND binding posts: 0360-1190. Add HP P/N for nylon nuts for mounting bindings posts: 2950-0144, qty. 6. Change HP P/N for meter bezels to: 4040-0571, gray, qty. 2. Add HP P/N for No. 6-32 nuts for mounting bezels: 2500-0001, qty. 4.

CHANGE 15:

In the replaceable parts list, page 6-5, under Fuse F1, add fuse F2, 3A, 250 VAC HP P/N 2110-0447, qty 1.

CHANGE 16:

In the replaceable parts list, page 6-6, change S1 previously changed in change to: S1, DPST, plastic, HP P/N 3101-2456, Qty. 1. In the replaceable parts list, page 6-6, change R52 to 16 k, .5 W, HP P/N 0686-1635.

ERRATA:

For all instruments delivered on or after July 1, 1978, change the HP P/N for fuseholder from 1400-0084 to fuseholder body 2100-0564 and fuseholder carrier 2100-0565. Change the HP P/N for fuseholder nut from 2950-0038 to 2100-0569. If old fuseholder must be replaced for any reason, replace complete fuseholder and nut with new fuseholder parts. Do not replace new parts with old parts.

ERRATA:

In the replaceable parts list, page 6-7, change Barrier Strip to HP P/N 0360-2185.

CHANGE 12:

On page 6-6, delete P.C. Board bracket HP P/N 5000-6088 and add P.C. Board bracket HP P/N 5000-3173. On page 6-7, change qty. of rubber bumper HP P/N 0403-0085 from 2 to 1.

CHANGE 17:

In the replaceable parts list, page 6-7, add the following assembly to the mechanical parts; Barrier Strip Guard Assembly, HP P/N 5060-2862, qty. 2.

CHANGE 18:

In the replaceable parts list, page 6-5, change Q6 to HP P/N 1854-1017, qty 2, and Q7 to HP P/N 1854-1096, qty 2. On the same page add C25, fxd poly, 0.003uf, 10%, 200V, HP P/N 0160-0155, qty 2. On the schematic C25 is added from Base to collector of transistor Q4 (ref. Driver and Error Amp Ckt).

ERRATA:

In the Operating and Service manual, for units with Option 040, add the following note.

NOTE

When calibrated for Option 040, units may not meet full output voltage or current specification when used with the front panel potentiometer. This is due to the resistance tolerance of the potentiometer and the programming coefficient accuracy required for Option 040.

ERRATA:

In the replaceable parts list for the front panel, delete light indicator HP P/N 1450-0566 (qty 1) and change the quantity of light indicator HP P/N 1450-0647 from 1 to 2. Also add, Retainer - push on; HP P/N 0510-0123 (qty 2).

Part numbers for Errata

DESCRIPTION	HP Part No.		
	STANDARD	OPTION A85	OPTION X95
Front Panel, Lettered	06255-60004	06255-60001	<-----
Heat Sink	5060-7967	<-----	5060-6128
Chassis, Right Side	5060-7953	<-----	5060-6129
Chassis, Left Side	5060-7954	<-----	5060-6130
Cover	5000-9428	<-----	5000-6089

SAFETY SUMMARY

The following general safety precautions must be observed during all phases of operation, service, and repair of this instrument. Failure to comply with these precautions or with specific warnings elsewhere in this manual violates safety standards of design, manufacture, and intended use of the instrument. Hewlett-Packard Company assumes no liability for the customer's failure to comply with these requirements.

BEFORE APPLYING POWER.

Verify that the product is set to match the available line voltage and the correct fuse is installed.

GROUND THE INSTRUMENT.

This product is a Safety Class 1 instrument (provided with a protective earth terminal). To minimize shock hazard, the instrument chassis and cabinet must be connected to an electrical ground. The instrument must be connected to the ac power supply mains through a three-conductor power cable, with the third wire firmly connected to an electrical ground (safety ground) at the power outlet. For instruments designed to be hard-wired to the ac power lines (supply mains), connect the protective earth terminal to a protective conductor before any other connection is made. Any interruption of the protective (grounding) conductor or disconnection of the protective earth terminal will cause a potential shock hazard that could result in personal injury. If the instrument is to be energized via an external autotransformer for voltage reduction, be certain that the autotransformer common terminal is connected to the neutral (earthed pole) of the ac power lines (supply mains).

INPUT POWER MUST BE SWITCH CONNECTED.

For instruments without a built-in line switch, the input power lines must contain a switch or another adequate means for disconnecting the instrument from the ac power lines (supply mains).

DO NOT OPERATE IN AN EXPLOSIVE ATMOSPHERE.

Do not operate the instrument in the presence of flammable gases or fumes.

KEEP AWAY FROM LIVE CIRCUITS.

Operating personnel must not remove instrument covers. Component replacement and internal adjustments must be made by qualified service personnel. Do not replace components with power cable connected. Under certain conditions, dangerous voltages may exist even with the power cable removed. To avoid injuries, always disconnect power, discharge circuits and remove external voltage sources before touching components.

DO NOT SERVICE OR ADJUST ALONE.

Do not attempt internal service or adjustment unless another person, capable of rendering first aid and resuscitation, is present.

DO NOT EXCEED INPUT RATINGS.

This instrument may be equipped with a line filter to reduce electromagnetic interference and must be connected to a properly grounded receptacle to minimize electric shock hazard. Operation at line voltages or frequencies in excess of those stated on the data plate may cause leakage currents in excess of 5.0 mA peak.

SAFETY SYMBOLS.



Instruction manual symbol: the product will be marked with this symbol when it is necessary for the user to refer to the instruction manual (refer to Table of Contents).



Indicates hazardous voltages.



or



Indicate earth (ground) terminal.

WARNING

The WARNING sign denotes a hazard. It calls attention to a procedure, practice, or the like, which, if not correctly performed or adhered to, could result in personal injury. Do not proceed beyond a WARNING sign until the indicated conditions are fully understood and met.

CAUTION

The CAUTION sign denotes a hazard. It calls attention to an operating procedure, or the like, which, if not correctly performed or adhered to, could result in damage to or destruction of part or all of the product. Do not proceed beyond a CAUTION sign until the indicated conditions are fully understood and met.

DO NOT SUBSTITUTE PARTS OR MODIFY INSTRUMENT.

Because of the danger of introducing additional hazards, do not install substitute parts or perform any unauthorized modification to the instrument. Return the instrument to a Hewlett-Packard Sales and Service Office for service and repair to ensure that safety features are maintained.

Instruments which appear damaged or defective should be made inoperative and secured against unintended operation until they can be repaired by qualified service personnel.

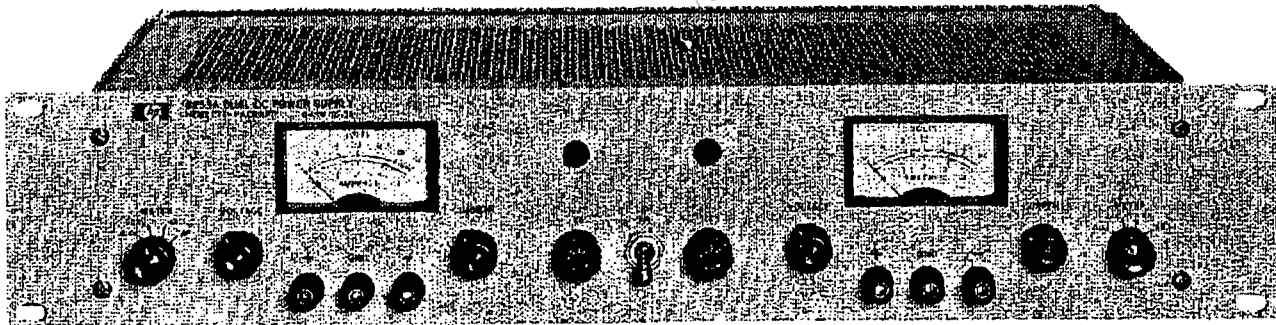

Figure 1-1. Typical DPR Series DC Power Supply

SECTION I
GENERAL INFORMATION

1-1 DESCRIPTION

1-2 This power supply, Figure 1-1, is completely transistorized and suitable for either rack or bench operation. It is a dual supply consisting of two independently controlled sections; both identical to each other. Each section is a well-regulated, Constant Voltage/Constant Current source that will furnish full rated output voltage at the maximum rated output current or can be continuously adjusted throughout either output range. The front panel CURRENT controls can be used to establish the output current limit (overload or short circuit) when the supply is used as a constant voltage source and the VOLTAGE control(s) can be used to establish the voltage limit (ceiling) when the supply is used as a constant current source. Each section will automatically crossover from constant voltage to constant current operation and vice versa if the output current or voltage exceeds these preset limits.

1-3 Each supply has both front and rear terminals. Either the positive or negative output terminal may be grounded or the power supply can be operated floating at up to a maximum of 300 volts off ground.

1-4 Each section has its own front panel meter and operating controls. The meters are of the multiple range type and can measure output voltage or current. The voltage or current ranges are selected by the applicable METER switch on the front panel.

1-5 Two sets of programming terminals located at the rear of the unit allow ease in adapting to the many operational capabilities of the power supply. A brief description of these capabilities is given below:

a. Remote Programming

The power supply may be programmed from a remote location by means of an external voltage source or resistance.

b. Remote Sensing

The degradation in regulation which would occur at the load because of the voltage drop in the load leads can be reduced by using the power

supply in the remote sensing mode of operation.

c. Series and Auto-Series Operation

Power supplies may be used in series when a higher output voltage is required in the voltage mode of operation or when greater voltage compliance is required in the constant current mode of operation. Auto-Series operation permits one knob control of the total output voltage from a "master" supply.

d. Parallel and Auto-Parallel Operation

The power supply may be operated in parallel with a similar unit when greater output current capability is required. Auto-Parallel operation permits one knob control of the total output current from a "master" supply.

e. Auto-Tracking

The power supply may be used as a "master" supply, having control over one (or more) "slave" supplies that furnish various voltages for a system.

1-6 SPECIFICATIONS

1-7 Detailed specifications for the power supply are given in Table 1-1.

NOTE

Since both sections of this supply are identical, only one section will be discussed throughout the remaining portions of this manual. All descriptions, illustrations, tests, and adjustments apply equally to both sections of the supply.

1-8 OPTIONS

1-9 Options are factory modifications of a standard instrument that are requested by the customer. The following options are available for the instrument covered by this manual. Where necessary, detailed coverage of the options is included throughout the manual.

<u>Option No.</u>	<u>Description</u>				
07	Voltage 10-Turn Pot: A single control that replaces both coarse and fine voltage controls and improves output settability. Standard item on Model 6258A power supplies.				
08	Current 10-Turn Pot: A single control that replaces both coarse and fine current controls and improves output settability.				
09	Voltage and Current 10-Turn Pot: Consists of Options 07 and 08 on the same instrument.				
10	Chassis Slides: Enables convenient access to power supply interior for maintenance purposes.				
11	Internal Overvoltage Protection "Crowbars": This option includes two crowbar circuits, one for each power supply within the 6253A or 6255A. Each crowbar protects delicate loads by monitoring the output voltage and firing an SCR that shorts the output when the preset trip voltage is exceeded. The circuit boards are factory installed within the supply. The "Crowbar Adjust" controls are mounted on the front panel to permit convenient adjustment. Trip Voltage Range: <table border="0" style="margin-left: 40px;"> <tr> <td style="text-align: center;"><u>6253A</u></td> <td style="text-align: center;"><u>6255A</u></td> </tr> <tr> <td style="text-align: center;">2.5 to 23V</td> <td style="text-align: center;">2.5 to 44V</td> </tr> </table> Trip Voltage Margin: The minimum crowbar trip setting above the desired operating output voltage to prevent false crowbar tripping is 4% of the output voltage setting +2V. Refer to Appendix A for complete details.	<u>6253A</u>	<u>6255A</u>	2.5 to 23V	2.5 to 44V
<u>6253A</u>	<u>6255A</u>				
2.5 to 23V	2.5 to 44V				

<u>Option No.</u>	<u>Description</u>
13	Three Digit Graduated Decadal Voltage Control: Control that replaces coarse and fine voltage controls permitting accurate resettability.
14	Three Digit Graduated Decadal Current Control: Control that replaces coarse and fine current controls permitting accurate resettability.
28	Rewire for 230V AC Input: Supply as normally shipped is wired for 115VAC input. Option 28 consists of reconnecting the input transformer for 230V AC operation.

1-10 INSTRUMENT IDENTIFICATION

1-11 Hewlett-Packard power supplies are identified by a three-part serial number tag. The first part is the power supply model number. The second part is the serial number prefix, which consists of a number-letter combination that denotes the date of a significant design change. The number designates the year, and the letter A through L designates the month, January through December, respectively. The third part is the power supply serial number.

1-12 If the serial number prefix on your power supply does not agree with the prefix on the title page of this manual, change sheets are included to update the manual. Where applicable, backdating information is given in an appendix at the rear of the manual.

1-13 ORDERING ADDITIONAL MANUALS

1-14 One manual is shipped with each power supply. Additional manuals may be purchased from your local Hewlett-Packard field office (see list at rear of this manual for addresses). Specify the model number, serial number prefix, and $\text{\textcircled{P}}$ stock number provided on the title page.

Table 1-1. Specifications

INPUT:

105-125/210-250 VAC, single phase,
50-400 cps.

OUTPUT:

Two independent outputs each of which can
be set at 0-40 volts @ 0-1.5 amps.

LOAD REGULATION:

Constant Voltage -- Less than 0.01% plus
2mv for a full load to no load change in output
current.

Constant Current -- Less than 0.01% plus
250 μ a for a zero to maximum change in output
voltage.

LINE REGULATION:

Constant Voltage -- Less than 0.01% plus
2mv for any line voltage change within the input
rating.

Constant Current -- Less than 0.01% plus
250 μ a for any line voltage change within the in-
put rating.

RIPPLE AND NOISE:

Constant Voltage -- Less than 200 μ v rms.

Constant Current -- Less than 500 μ a rms.

TEMPERATURE RANGES:

Operating: 0 to 50°C. Storage: -20 to +85°C.

TEMPERATURE COEFFICIENT:

Constant Voltage -- Less than 0.02% plus
500 μ v per degree Centigrade.

Constant Current -- Less than 0.02% plus
0.8ma per degree Centigrade.

STABILITY:

Constant Voltage -- Less than 0.10% plus
2.5mv total drift for 8 hours after an initial warm-
up time of 30 minutes at constant ambient, con-
stant line voltage, and constant load.

Constant Current -- Less than 0.10% plus
4ma total drift for 8 hours after an initial warm-up
time of 30 minutes at constant ambient, constant
line voltage, and constant load.

**INTERNAL IMPEDANCE AS A CONSTANT VOLTAGE
SOURCE:**

Less than 0.001 ohm from DC to 100 Hz.

Less than 0.01 ohm from 100 Hz to 1 kHz.

Less than 0.2 ohm from 1 kHz to 100 kHz.

Less than 2.0 ohms from 100 kHz to 1 MHz.

TRANSIENT RECOVERY TIME:

Less than 50 μ sec for output recovery to within
15 mv following a full load current change in the
output.

OVERLOAD PROTECTION:

A continuously acting constant current circuit
protects the power supply for all overloads in-
cluding a direct short placed across the termi-
nals in constant voltage operation. The constant
voltage circuit limits the output voltage in the
constant current mode of operation.

METERS:

Each front panel meter can be used as either a
0-50V or 0-5 volt voltmeter or as a 0-1.8A or
0-0.18 amp ammeter.

OUTPUT CONTROLS:

Coarse and fine voltage controls and coarse
and fine current controls set desired output volt-
age or current.

OUTPUT TERMINALS:

Six "five-way" output posts (three per section)
are provided on the front panel and output terminal
strips are located on the rear of the chassis. All
power supply output terminals are isolated from
the chassis and either the positive or negative
terminals may be connected to the chassis
through a separate ground terminal located on the
output terminal strip.

ERROR SENSING:

Error sensing is normally accomplished at the
front terminals if the load is attached to the front
or at the rear terminals if the load is attached to
the rear terminals. Also, provision is included
on the rear terminal strip for remote sensing.

REMOTE PROGRAMMING:

Remote programming of the supply output at ap-
proximately 200 ohms per volt in constant voltage
is made available at the rear terminals. In con-
stant current mode of operation, the current can
be remotely programmed at approximately 500 ohms
per ampere.

COOLING:

Convection cooling is employed. The supply
has no moving parts.

SIZE:

3 - 1/2" H x 14 - 1/2" D x 19" W. Easily rack
mounted in a standard 19" relay rack.

WEIGHT:

28 lbs. net, 35 lbs. shipping.

FINISH:

Light gray front panel with dark gray case.

POWER CORD:

A three-wire, five-foot power cord is provided
with each unit.

SECTION II INSTALLATION

2-1 INITIAL INSPECTION

2-2 Before shipment, this instrument was inspected and found to be free of mechanical and electrical defects. As soon as the instrument is unpacked, inspect for any damage that may have occurred in transit. Save all packing materials until the inspection is completed. If damage is found, proceed as described in the Claim for Damage in Shipment section of the warranty page at the rear of this manual.

2-3 MECHANICAL CHECK

2-4 This check should confirm that there are no broken knobs or connectors, that the cabinet and panel surfaces are free of dents and scratches, and that the meter is not scratched or cracked.

2-5 ELECTRICAL CHECK

2-6 The instrument should be checked against its electrical specifications. Section V includes an "in-cabinet" performance check to verify proper instrument operation.

2-7 INSTALLATION DATA

2-8 The instrument is shipped ready for bench operation. It is necessary only to connect the instrument to a source of power and it is ready for operation.

2-9 LOCATION

2-10 This instrument is air cooled. Sufficient space should be allotted so that a free flow of cooling air can reach the sides and rear of the instrument when it is in operation. It should be used in an area where the ambient temperature does not exceed 50°C.

2-11 RACK MOUNTING

2-12 This instrument is full rack size and can be easily rack mounted in a conventional 19 inch rack panel using standard mounting screws.

2-13 INPUT POWER REQUIREMENTS

2-14 This power supply may be operated from

either a nominal 115 volt or 230 volt 50-400 cycle power source. The unit, as shipped from the factory, is wired for 115 volt operation. The input power required when operated from a 115 volt 60 cycle power source at full load is 235 watts and 2.6 amperes.

2-15 CONNECTIONS FOR 230 VOLT OPERATION (Figure 2-1)

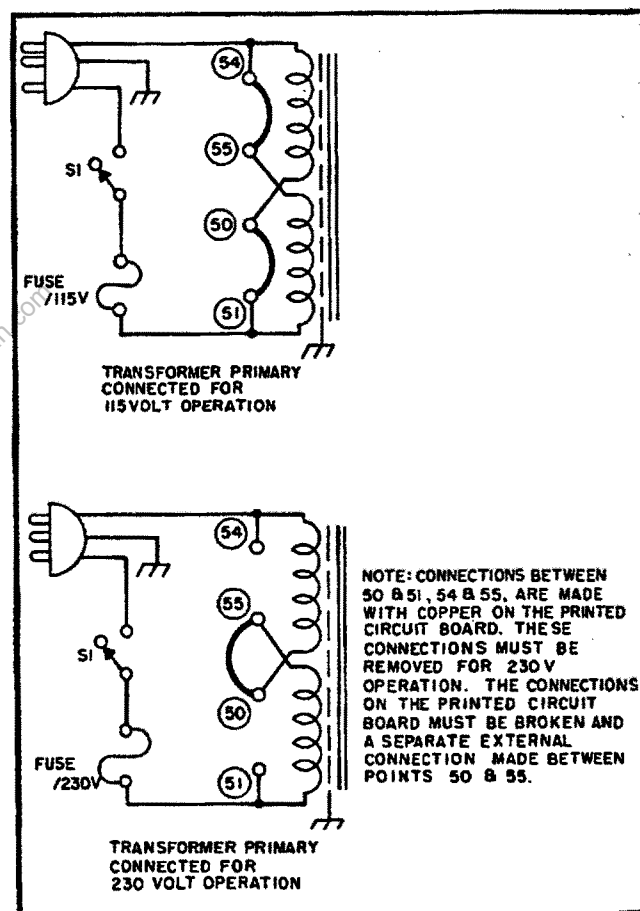

Figure 2-1. Primary Connections

2-16 Normally, the two primary windings of the input transformer are connected in parallel for operation from 115 volt source. To convert the power supply to operation from a 230 volt source, the power transformer windings are connected in series as follows:

- a. Unplug the line cord and remove the unit covers.
- b. Break the copper between 54 and 55 and also between 50 and 51 on the printed circuit board. These are shown in Figure 2-1, and are labeled on copper side of printed circuit board.
- c. Add strap between 50 and 55.
- d. Replace existing fuse with 2 ampere, 230 volt fuse. Return unit to case and operate normally.

2-17 POWER CABLE

2-18 To protect operating personnel, the National Electrical Manufacturers Association (NEMA) recommends that the instrument panel and cabinet be grounded. This instrument is equipped with a three conductor power cable. The third conductor is the ground conductor and when the cable is plugged into an appropriate receptacle, the instrument is grounded. The offset pin on the power

cable three-prong connector is the ground connection.

2-19 To preserve the protection feature when operating the instrument from a two-contact outlet, use a three-prong to two-prong adapter and connect the green lead on the adapter to ground.

2-20 REPACKAGING FOR SHIPMENT

2-21 To insure safe shipment of the instrument, it is recommended that the package designed for the instrument be used. The original packaging material is reusable. If it is not available, contact your local Hewlett-Packard field office to obtain the materials. This office will also furnish the address of the nearest service office to which the instrument can be shipped. Be sure to attach a tag to the instrument which specifies the owner, model number, full serial number, and service required, or a brief description of the trouble.

<http://www.ebaman.com>

SECTION III OPERATING INSTRUCTIONS

3-1 OPERATING CONTROLS AND INDICATORS

3-2 The front panel controls and indicators, together with the normal turn-on sequence, are shown in Figure 3-1.

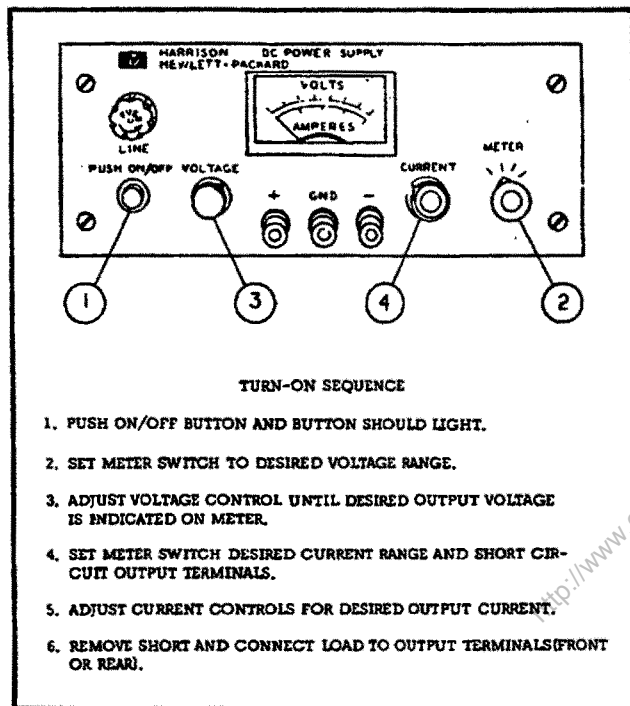

Figure 3-1. Front Panel Controls and Indicators

3-3 OPERATING MODES

3-4 The power supply is designed so that its mode of operation can be selected by making strapping connections between particular terminals on the terminal strip at the rear of the power supply. The terminal designations are stenciled in white on the power supply above their respective terminals. Although the strapping patterns illustrated in this section show the positive terminal grounded, the operator can ground either terminal or operate the power supply up to 300Vdc off ground (floating). The following paragraphs describe the procedures for utilizing the various operational capabilities of the power supply. A more theoretical description concerning the operational features of this supply is contained in Application Note 90, DC Power Supply Handbook, which may be obtained from your local Hewlett-Packard field sales office.

3-5 NORMAL OPERATING MODE

3-6 The power supply is normally shipped with its rear terminal strapping connections arranged for Constant Voltage/Constant Current, local sensing, local programming, single unit mode of operation. This strapping pattern is illustrated in Figure 3-2. The operator selects either a constant voltage or a constant current output using the front panel controls (local programming, no strapping changes are necessary).

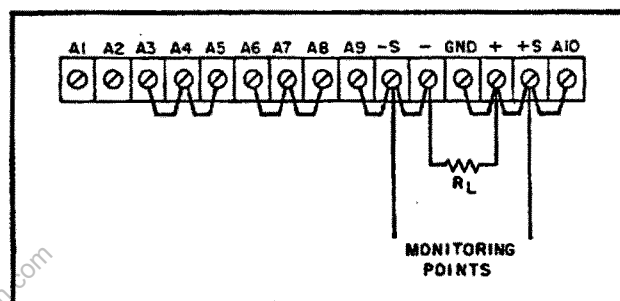

Figure 3-2. Normal Strapping Pattern

3-7 CONSTANT VOLTAGE

3-8 To select a constant voltage output, proceed as follows:

- a. Turn-on power supply and adjust VOLTAGE controls for desired output voltage (output terminals open).
- b. Short output terminals and adjust CURRENT controls for maximum output current allowable (current limit), as determined by load conditions. If a load change causes the current limit to be exceeded, the power supply will automatically cross-over to constant current output at the preset current limit and the output voltage will drop proportionately. In setting the current limit, allowance must be made for high peak current which can cause unwanted cross-over. (Refer to Paragraph 3-46.)

3-9 CONSTANT CURRENT

3-10 To select a constant current output, proceed as follows:

- a. Short output terminals and adjust CURRENT controls for desired output current.
- b. Open output terminals and adjust VOLTAGE controls for maximum output voltage allowable (voltage limit), as determined by load conditions. If a

load change causes the voltage limit to be exceeded, the power supply will automatically crossover to constant voltage output at the preset voltage limit and the output current will drop proportionately. In setting the voltage limit, allowance must be made for high peak voltages which can cause unwanted crossover. (Refer to Paragraph 3-46.)

3-11 CONNECTING LOAD

3-12 Each load should be connected to the power supply output terminals using separate pairs of connecting wires. This will minimize mutual coupling effects between loads and will retain full advantage of the low output impedance of the power supply. Each pair of connecting wires should be as short as possible and twisted or shielded to reduce noise pickup. (If shield is used, connect one end to power supply ground terminal and leave the other end unconnected.)

3-13 If load considerations require that the output power distribution terminals be remotely located from the power supply, then the power supply output terminals should be connected to the remote distribution terminals via a pair of twisted or shielded wires and each load separately connected to the remote distribution terminals. For this case, remote sensing should be used (Paragraph 3-20).

3-14 OPERATION OF SUPPLY BEYOND RATED OUTPUT

3-15 The shaded area on the front panel meter face indicates the amount of output voltage or current that is available in excess of the normal rated output. Although the supply can be operated in this shaded region without being damaged, it cannot be guaranteed to meet all of its performance specifications. However, if the line voltage is maintained above 115 Vac, the supply will probably operate within its specifications.

3-16 OPTIONAL OPERATING MODES

3-17 REMOTE PROGRAMMING, CONSTANT VOLTAGE

3-18 The constant voltage output of the power supply can be programmed (controlled) from a remote location if required. Either a resistance or voltage source can be used for the programming device. The wires connecting the programming terminals of the supply to the remote programming device should be twisted or shielded to reduce noise pick-up. The VOLTAGE controls on the front panel are disabled according to the following procedures.

3-19 Resistance Programming (Figure 3-3). In this mode, the output voltage will vary at a rate determined by the programming coefficient (200 ohms per Volt for Models 6253A, 6255A, 6281A, 6284A, and 6289A or 300 ohms per Volt for Models 6294A and

6299A). The output voltage will increase 1 Volt for each 200 ohms (or 300 ohms) added in series with the programming terminals. The programming coefficient is determined by the programming current. This current is factory adjusted to within 2% of 5mA for Models 6253A, 6255A, 6281A, 6284A, and 6289A or 2% of 3.3mA for Models 6294A and 6299A. If greater programming accuracy is required, it may be achieved by changing resistor R13.

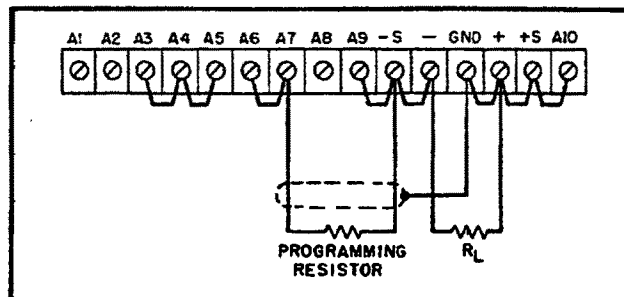

Figure 3-3. Remote Resistance Programming (Constant Voltage)

3-20 The output voltage of the power supply should be zero Volts ± 20 millivolts when zero ohms is connected across the programming terminals. If a zero ohm voltage closer than this is required, it may be achieved by changing resistor R6 or R8 as described in Paragraph 5-59.

3-21 To maintain the stability and temperature coefficient of the power supply, use programming resistors that have stable, low noise, and low temperature (less than 30 ppm per degree Centigrade) characteristics. A switch can be used in conjunction with various resistance values in order to obtain discrete output voltages. The switch should have make-before-break contacts to avoid momentarily opening the programming terminals during the switching interval.

3-22 Voltage Programming (Figure 3-4). Employ the strapping pattern shown on Figure 3-4 for

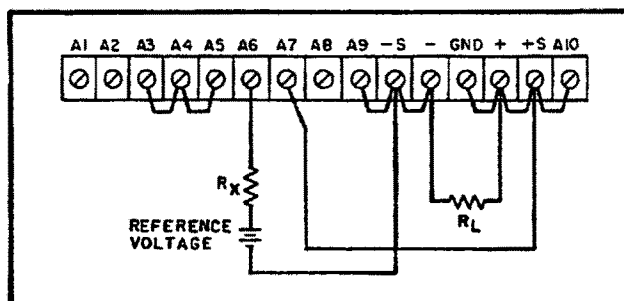

Figure 3-4. Remote Voltage Programming (Constant Voltage)

voltage programming. In this mode, the output voltage will vary in a 1 to 1 ratio with the programming voltage (reference voltage) and the load on the programming voltage source will not exceed 25mA.

3-23 The impedance matching resistor (R_x) for the programming voltage source should be approximately 500 ohms to maintain the temperature and stability specifications of the power supply.

3-24 REMOTE PROGRAMMING, CONSTANT CURRENT

3-25 Either a resistance or a voltage source can be used to control the constant current output of the supply. The CURRENT controls on the front panel are disabled according to the following procedures.

3-26 Resistance Programming (Figure 3-5). In this mode, the output current varies at a rate determined by the programming coefficient — 200 ohms per Amp for Model 6281A, 500 ohms per Ampere for Models 6253A, 6255A, 6284A, and 6289A, and 1000 ohms per Ampere for Models 6294A and 6299A. The programming coefficient is determined by the Constant Current programming current (2mA for Models 6253A, 6255A, 6284A, and 6289A, 5mA for Model 6281A, 1mA for Model 6294A and 1.33mA for Model 6299A). This current is adjusted to within 10% at the factory. If greater programming accuracy is required, it may be achieved by changing resistor R19 as outlined in Section V.

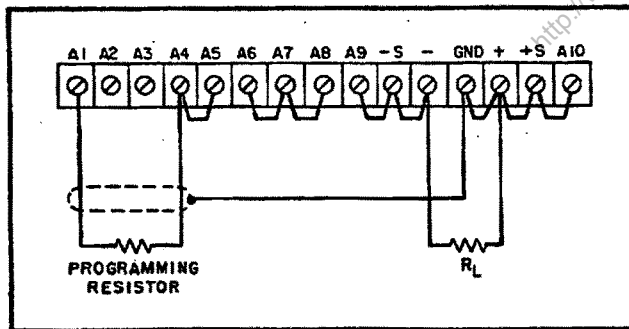

Figure 3-5. Remote Resistance Programming (Constant Current)

3-27 Use stable, low noise, low temperature coefficient (less than 30ppm/°C) programming resistors to maintain the power supply temperature coefficient and stability specifications. A switch may be used to set discrete values of output current. A make-before-break type of switch should be used since the output current will exceed the maximum rating of the power supply if the switch contacts open during the switching interval.

CAUTION

If the programming terminals (A1 and A5) should open at any time during this mode, the output current will rise to a value that may damage the power supply and/or the load. To avoid this possibility, connect a resistor across the programming terminals having the value listed below. Like the programming resistor, this resistor should be of the low noise, low temperature coefficient type.

Model	6253A, 6284A	6255A, 6289A, 6299A
Resistance	1.5K Ω	750 Ω

Model	6281A, 6294A
Resistance	1K Ω

3-28 Voltage Programming (Figure 3-6). In this mode, the output current will vary linearly with changes in the programming voltage. The programming voltage should not exceed 1.2 Volts. Voltage in excess of 1.2 Volts will result in excessive power dissipation in the instrument and possible damage.

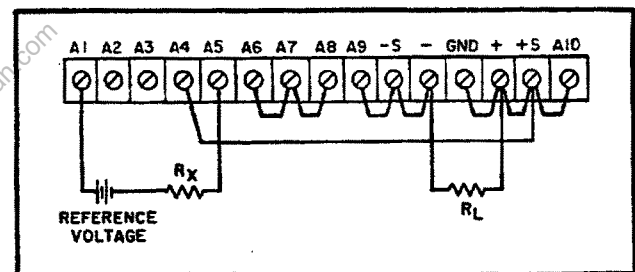

Figure 3-6. Remote Voltage Programming (Constant Current)

3-29 The output current will be the programming voltage divided by 1 ohm. The current required from the voltage source will be less than 25 microamperes. The impedance matching resistor (R_x) should be approximately 500 ohms if the temperature coefficient and stability specifications of the power supply are to be maintained.

3-30 REMOTE SENSING (See Figure 3-7)

3-31 Remote sensing is used to maintain good regulation at the load and reduce the degradation of regulation which would occur due to the voltage drop in the leads between the power supply and the load. Remote sensing is accomplished by utilizing the strapping pattern shown in Figure 3-7. The power supply should be turned off before changing strap-

ping patterns. The leads from the +S terminals to the load will carry less than 10mA of current, and it is not required that these leads be as heavy as the load leads. However, they must be twisted or shielded to minimize noise pick-up.

CAUTION

Observe polarity when connecting the sensing leads to the load.

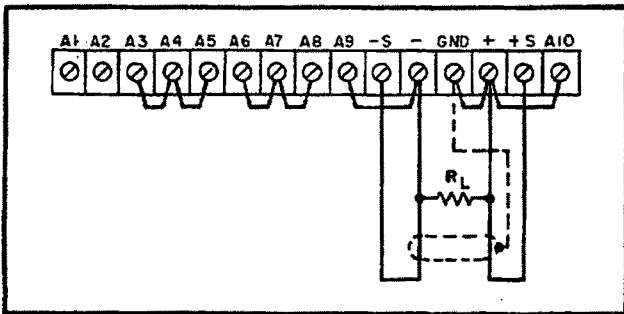

Figure 3-7. Remote Sensing

3-32 Note that it is desirable to minimize the drop in the load leads and it is recommended that the drop not exceed 1 Volt per lead if the power supply is to meet its dc specifications. If a larger drop must be tolerated, please consult a Hewlett-Packard field representative.

NOTE

Due to the voltage drop in the load leads, it may be necessary to readjust the current limit in the remote sensing mode.

3-33 The procedure just described will result in a low dc output impedance at the load. If a low ac impedance is required, it is recommended that the following precautions be taken:

- a. Disconnect output capacitor C20 by disconnecting the strap between A9 and -S.
- b. Connect a capacitor having similar characteristics (approximately same capacitance, same voltage rating or greater, and having good high frequency characteristics) across the load using short leads.

3-34 Although the strapping patterns shown in Figures 3-3 through 3-6 employ local sensing, note that it is possible to operate a power supply simultaneously in the remote sensing and Constant Voltage/Constant Current remote programming modes.

3-35 **SERIES OPERATION**

3-36 Normal Series Connections (Figure 3-8). Two

or more power supplies can be operated in series to obtain a higher voltage than that available from a single supply. When this connection is used, the output voltage is the sum of the voltages of the individual supplies. Each of the individual supplies must be adjusted in order to obtain the total output voltage. The power supply contains a protective diode connected internally across the output which protects the supply if one power supply is turned off while its series partner(s) is on.

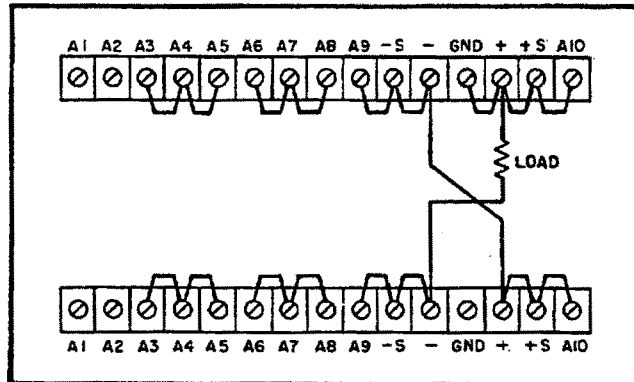

Figure 3-8. Normal Series Connections

3-37 Auto-Series Connections (Figure 3-9). The Auto-Series configuration is used when it is desirable to have the output voltage of each of the series connected supplies vary in accordance with the setting of a control unit. The control unit is called the master; the controlled units are called slaves. At maximum output voltage, the voltage of the slaves is determined by the setting of the front panel VOLTAGE control on the master. The master supply must be the most positive supply of the series. The output CURRENT controls of all series units are operative and the current limit is equal to the lowest control setting. If any output CURRENT controls are set too low, automatic crossover to constant current operation will occur and the output voltage will drop. Remote sensing and programming can be used; however, the strapping arrangements shown in the applicable figures show local sensing and programming.

3-38 In order to maintain the temperature coefficient and stability specifications of the power supply, the external resistors (Rx) shown in Figure 3-9 should be stable, low noise, low temperature coefficient (less than 30 ppm per degree Centigrade) resistors. The value of each resistor is dependant on the maximum voltage rating of the "master" supply. The value of Rx is this voltage divided by the voltage programming current of the slave supply ($1/K_p$ where K_p is the voltage programming coefficient). The voltage contribution of the slave is determined by its voltage control setting.

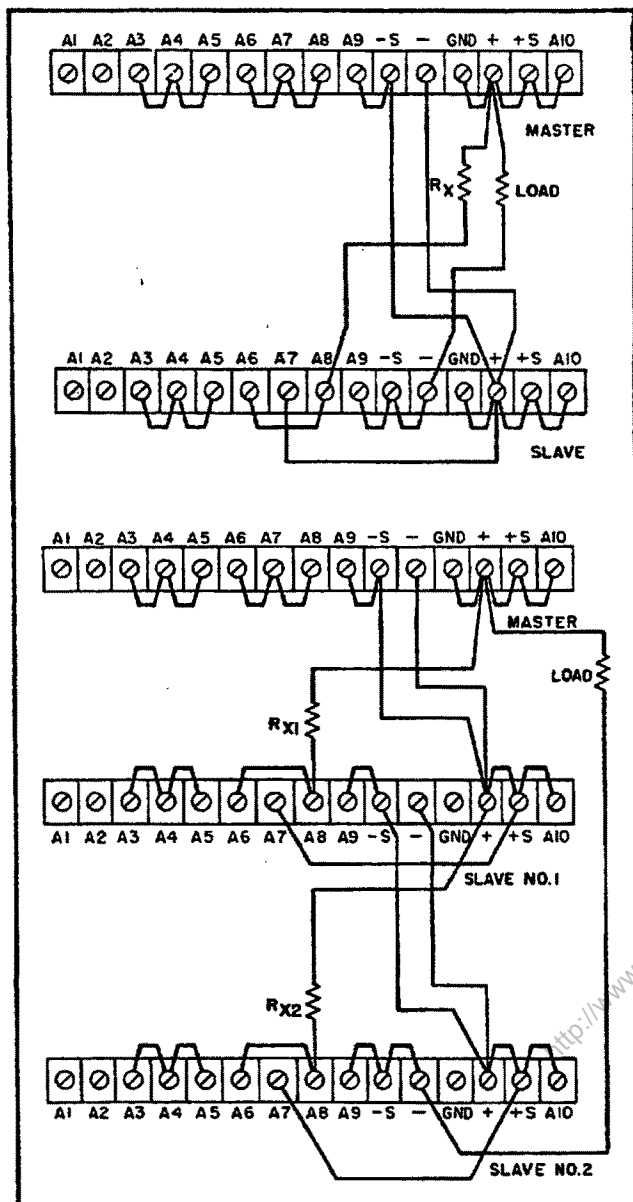

Figure 3-9. Auto-Series, Two and Three Units

3-39 PARALLEL OPERATION

3-40 Normal Parallel Connections (Figure 3-10).

Two or more power supplies can be connected in parallel to obtain a total output current greater than that available from one power supply. The total output current is the sum of the output currents of the individual power supplies. The output CURRENT controls of each power supply can be separately set. The output VOLTAGE controls of one power supply should be set to the desired output voltage; the other power supply should be set for a slightly larger output voltage. The supply set to the lower output voltage will act as a constant voltage source; the supply set to the higher output voltage will act as a constant current set source, dropping its output

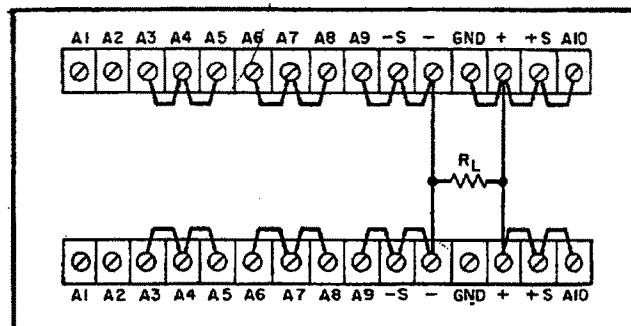

Figure 3-10. Normal Parallel Connections

voltage until it equals that of the other supply. The constant voltage source will deliver only that fraction of its total rated output current which is necessary to fulfill the total current demand.

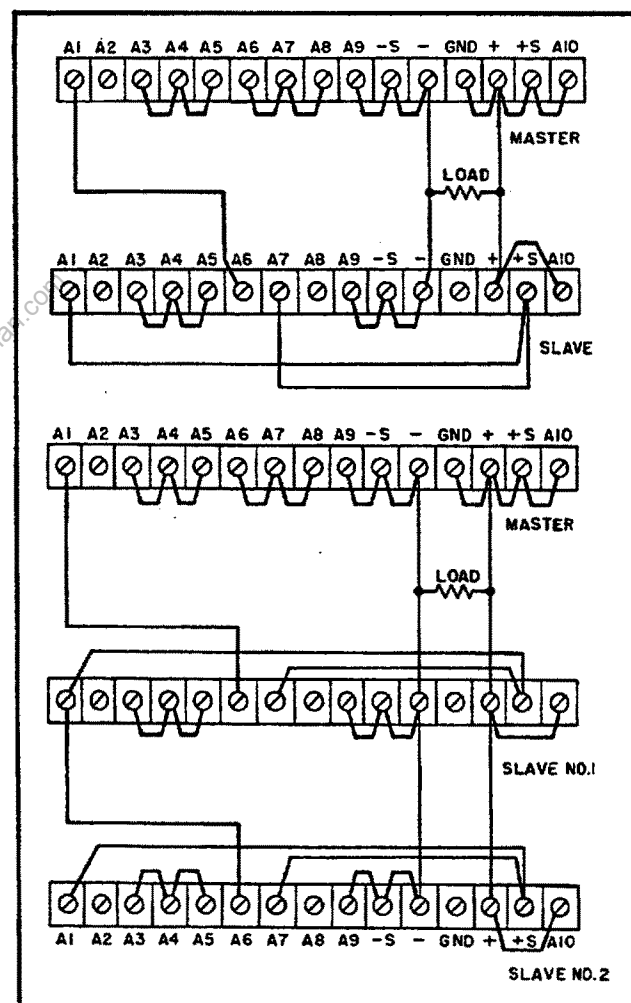

Figure 3-11. Auto-Parallel, Two and Three Units

3-41 Auto-Parallel. The strapping patterns for Auto-Parallel operation of two power supplies are shown in Figure 3-11. Auto-Parallel operation permits equal current sharing under all load con-

ditions, and allows complete control of output current from one master power supply. The output current of each slave will be approximately equal to the master's regardless of the load conditions. Because the output current controls of each slave are operative, they should be set to maximum to avoid having the slave revert to constant current operation; this would occur if the master output current setting exceeded the slave's.

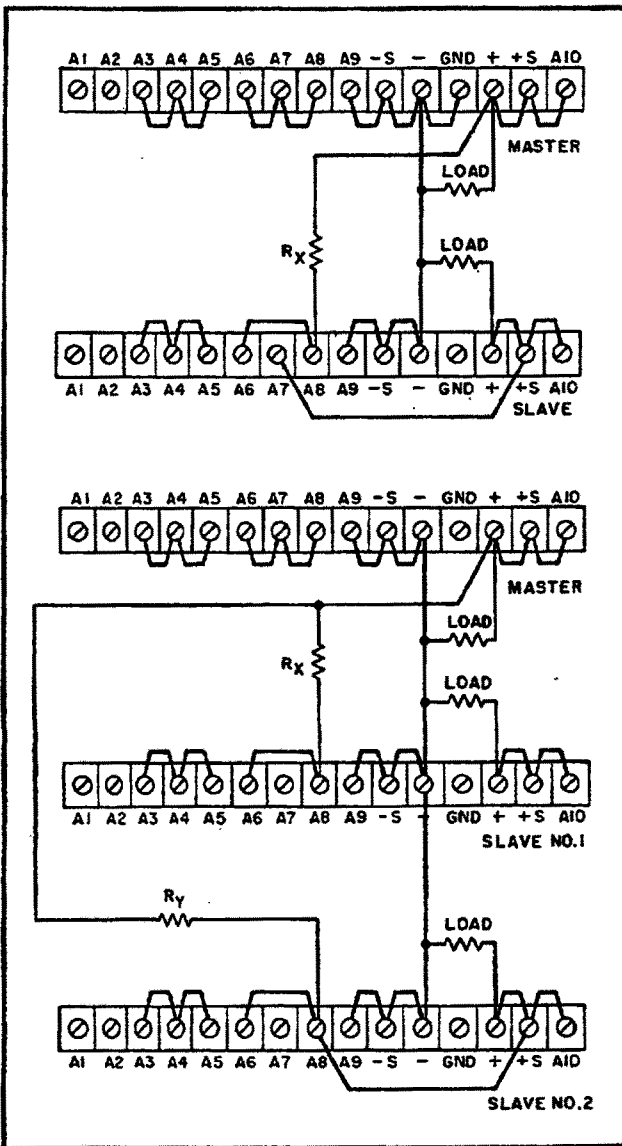

Figure 3-12. Auto-Tracking, Two and Three Units

3-42 AUTO-TRACKING OPERATION (See Figure 3-12)

3-43 The Auto-Tracking configuration is used when it is necessary that several different voltages referred to a common bus, vary in proportion to the setting of a particular instrument (the control or

master). A fraction of the master's output voltage is fed to the comparison amplifier of the slave supply, thus controlling the slave's output. The master must have the largest output voltage of any power supply in the group (must be the most positive supply in the example shown on Figure 3-12).

3-44 The output voltage of the slave is a percentage of the master's output voltage, and is determined by the voltage divider consisting of R_X (or R_X and R_Y) and the voltage control of the slave supply, R_p , where: $E_S = E_M R_p / R_X + R_p$. Turn-on and turn-off of the power supplies is controlled by the master. Remote sensing and programming can be used; although the strapping patterns for these modes show only local sensing and programming. In order to maintain the temperature coefficient and stability specifications of the power supply, the external resistors should be stable, low noise, low temperature (less than 30ppm per °C) resistors.

3-45 SPECIAL OPERATING CONSIDERATIONS

3-46 PULSE LOADING

3-47 The power supply will automatically crossover from constant voltage to constant current operation, or the reverse, in response to an increase (over the preset limit) in the output current or voltage, respectively. Although the preset limit may be set higher than the average output current or voltage, high peak currents or voltages (as occur in pulse loading) may exceed the preset limit and cause crossover to occur. If this crossover limiting is not desired, set the preset limit for the peak requirement and not the average.

3-48 OUTPUT CAPACITANCE

3-49 An internal capacitor, connected across the output terminals of the power supply, helps to supply high-current pulses of short duration during constant voltage operation. Any capacitance added externally will improve the pulse current capability, but will decrease the safety provided by the constant current circuit. A high-current pulse may damage load components before the average output current is large enough to cause the constant current circuit to operate.

3-50 The effects of the output capacitor during constant current operation are as follows:

- The output impedance of the power supply decreases with increasing frequency.
- The recovery time of the output voltage is longer for load resistance changes.
- A large surge current causing a high power dissipation in the load occurs when the load resistance is reduced rapidly.

3-51 REVERSE VOLTAGE LOADING

3-52 A diode is connected across the output terminals. Under normal operating conditions, the diode is reverse biased (anode connected to negative terminal). If a reverse voltage is applied to the output terminals (positive voltage applied to negative terminal), the diode will conduct, shunting current across the output terminals and limiting the voltage to the forward voltage drop of the diode. This diode protects the series transistors and the output electrolytic capacitor.

3-53 REVERSE CURRENT LOADING

3-54 Active loads connected to the power supply may actually deliver a reverse current to the power supply during a portion of its operating cycle. An external source cannot be allowed to pump current into the supply without loss of regulation and possible damage to the output capacitor. To avoid these effects, it is necessary to preload the supply with a dummy load resistor so that the power supply delivers current through the entire operating cycle of the load device.

<http://www.ebaman.com>

SECTION IV
PRINCIPLES OF OPERATION

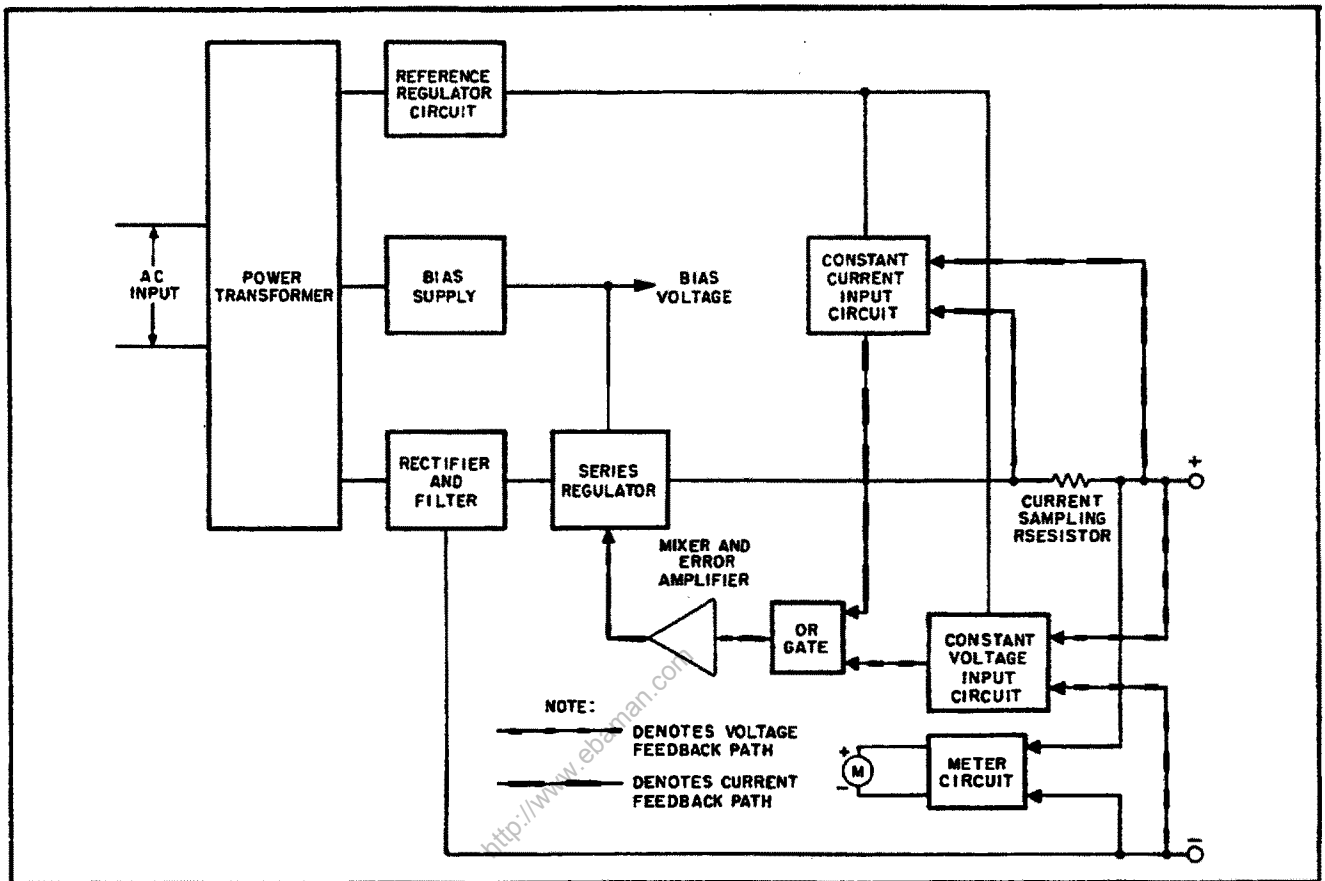

Figure 4-1. Overall Block Diagram

4-1 OVERALL BLOCK DIAGRAM DISCUSSION

4-2 The power supply, as shown on the overall block diagram on Figure 4-1, consists of a power transformer, a rectifier and filter, a series regulator, the mixer and error amplifiers, an "OR" gate, a constant voltage input circuit, a constant current input circuit, a reference regulator circuit, a bias supply, and a metering circuit.

4-3 The input line voltage passes through the power transformer to the rectifier and filter. The rectifier-filter converts the AC input to raw DC which is fed to the positive terminal via the regulator and current sampling resistor network. The regulator, part of the feedback loop, is made to alter its conduction to maintain a constant output voltage or current. The voltage developed

across the current sampling resistor network is the input to the constant current input circuit. The constant voltage input circuit obtains its input by sampling the output voltage of the supply.

4-4 Any changes in output voltage/current are detected in the constant voltage/constant current input circuit, amplified by the mixer and error amplifiers, and applied to the series regulator in the correct phase and amplitude to counteract the change in output voltage/output current. The reference circuit provides stable reference voltages which are used by the constant voltage/current input circuits for comparison purposes. The bias supply furnishes voltages which are used throughout the instrument for biasing purposes. The meter circuit provides an indication of output voltage or current for both operating modes.

4-8 DETAILED CIRCUIT ANALYSIS (Refer to overall schematic diagram at rear of manual)

4-9 FEEDBACK LOOP

4-10 The feedback loop functions continuously to keep the output voltage constant, during constant voltage operation, and the output current constant, during constant current operation. For purposes of this discussion, assume that the unit is in constant voltage operation and that the programming resistors R10 A and B have been adjusted so that the supply is yielding the desired output voltage. Further assume that the output voltage instantaneously rises (goes positive) due to a variation in the external load circuit.

4-11 Note that the change may be in the form of a slow rise in the output voltage or a positive going AC signal. An AC signal is coupled to summing point A6 through capacitor C1 and a DC voltage is coupled to A6 through R10.

4-12 The rise in output voltage causes the voltage at A6 and thus the base of Q1A to decrease (go negative). Q1A now decreases its conduction and its collector voltage rises. The positive going error voltage is amplified and inverted by Q3 and fed to the bases of series transistors Q6 and Q7 via emitter followers Q5 and Q4. The negative going input causes Q6 and Q7 to decrease their conduction so that they drop more of the line voltage, and reduce the output voltage to its original level.

4-13 If the external load resistance is decreased to a certain crossover point, the output current increases until transistor Q2A begins to conduct. During this time, the output voltage has also decreased to a level so that the base of Q1A is at a high positive potential. With Q1A in full conduction, its collector voltage decreases by the amount necessary to back bias OR gate diode CR3 and the supply is now in the constant current mode of operation. The crossover point at which constant current operation commences is determined by the setting of CURRENT control R16. The operation of the feedback loop during the constant current operating mode is similar to that occurring during constant voltage operation except that the input to the differential amplifier comparison circuit is obtained from the current sampling resistor network.

4-14 SERIES REGULATOR

4-15 The series regulator consists of transistor stages Q6 and Q7 (see schematic at rear of manual). Transistor Q6 is the series element, or pass transistor, which controls the output. Transistor Q7, together with shunt resistors R81, R82, and R83, are connected in a manner which minimizes the power

dissipated in series transistor Q6. The bias voltage for Q7 is developed across zener diode VR5. The conduction of Q7 will decrease as the collector-to-emitter voltage of Q6 approaches the voltage developed across the biasing diodes. At low output voltages Q7 is completely cutoff and all of the load current flows through the shunt resistors. The voltage that is dropped across Q7 and the shunt resistors reduces the voltage dropped across Q6, thus diminishing its power dissipation. The reliability of the regulator is further increased by mounting the shunt resistors outside the rear of the cabinet so that the internal components are operated under lower temperature conditions. Diode CR11, connected across Q6, protects it from reverse voltages that could develop across it during parallel or auto-parallel operation if one supply is turned on before the other. Diodes CR18 and CR19 perform a similar function for Q7.

4-16 CONSTANT VOLTAGE INPUT CIRCUIT

4-17 The circuit consists of programming resistor R10A and B, and a differential amplifier stage (Q1 and associated components). Transistor Q1 consists of two transistors housed in a single package. The transistors have matched characteristics minimizing differential voltages due to mismatched stages. Moreover, drift due to thermal differentials is minimized, since both transistors operate at essentially the same temperature.

4-18 The constant voltage input circuit continuously compares a fixed reference voltage with a portion of the output voltage and, if a difference exists, produces an error voltage whose amplitude and phase is proportional to the difference. The error output is fed back to the series regulator, through an OR gate and the mixer/error amplifiers. The error voltage changes the conduction of the series regulator which, in turn, alters the output voltage so that the difference between the two input voltages applied to the differential amplifier is reduced to zero. The above action maintains the output voltage constant.

4-19 Stage Q1B of the differential amplifier is connected to a common (+S) potential through impedance equalizing resistor R5. Resistors R6 and R8 are used to zero bias the input stage, offsetting minor base-to-emitter voltage differences in Q1. The base of Q1A is connected to a summing point at the junction of the programming resistor and the current pullout resistor, R12. Instantaneous changes in output voltage result in an increase or decrease in the summing point potential. Q1A is then made to conduct more or less, in accordance with the summing point voltage change. The resultant output error voltage is fed back to the series regulator via OR-gate diode CR3 and the

remaining components of the feedback loop. Resistor R1, in series with the base of Q1A, limits the current through the programming resistor during rapid voltage turn-down. Diodes CR1 and CR2 form a limiting network which prevent excessive voltage excursions from over driving stage Q1A. Capacitors C1 and C2, shunting the programming resistors, increase the high frequency gain of the input amplifier. Resistor R13, shunting pullout resistor R12, serves as a trimming adjustment for the programming current.

4-20 CONSTANT CURRENT INPUT CIRCUIT

4-21 This circuit is similar in appearance and operation to the constant voltage input circuit. It consists basically of the current programming resistors R16A and B, and a differential amplifier stage (Q2 and associated components). Like transistor Q1 in the voltage input circuit, Q2 consists of two transistors, having matched characteristics, that are housed in a single package.

4-22 The constant current input circuit continuously compares a fixed reference voltage with the voltage drop across the current sampling resistors R54 and R55. If a difference exists, the differential amplifier produces an error voltage which is proportional to this difference. The remaining components in the feedback loop (amplifiers and series regulator) function to maintain the drop across the current sampling resistors, and consequently the output current, at a constant value.

4-23 Stage Q2B is connected to a common (+S) potential through impedance equalizing resistor R26. Resistors R25 and R28 are used to zero bias the input stage, offsetting minor base-to-emitter voltage differences in Q2. Instantaneous changes in output current on the positive line are felt at the current summing point and, hence, the base of Q2A. Stage Q2A varies its conduction in accordance with the polarity of the change at the summing point. The change in Q2A's conduction also varies the conduction of Q2B due to the coupling effects of the common emitter resistor, R22. The error voltage is taken from the collector of Q2B and fed back to the series regulator through OR-gate diode CR4 and the remaining components of the feedback loop. The error voltage then varies the conduction of the regulator so that the output current is maintained at the proper level.

4-24 Resistor R20, in conjunction with R21 and C3 helps stabilize the feedback loop. Diode CR5 limits voltage excursions on the base of Q2A. Resistor R19, shunting the pullout resistor, serves as a trimming adjustment for the programming current flowing through R16.

4-25 VOLTAGE CLAMP CIRCUIT

4-26 During constant current operation the constant voltage programming resistors are a shunt load across the output terminals of the power supply. If the output voltage changed, the current through these resistors would tend to change resulting in an output current change. The clamp circuit is a return path for the voltage programming current, the current that normally flows through the programming resistors. The circuit maintains the current into the constant voltage summing point (A6) constant, thus eliminating the error due to shunting effects of the constant voltage programming resistors.

4-27 The voltage divider, R51, R52, and VR3, back biases CR30 and Q10 during constant voltage operation. When the power supply goes into constant current operation, CR30 becomes forward biased by the collector voltage of Q1A. This results in conduction of Q10 and the clamping of the summing point at a potential only slightly more negative than the normal constant voltage potential. Clamping this voltage at approximately the same potential that exists in constant voltage operation, results in a constant voltage across, and consequently a constant current through the pullout resistor (R12).

4-28 MIXER AND ERROR AMPLIFIERS

4-29 The mixer and error amplifiers amplify the error signal from the constant voltage or constant current input circuit to a level sufficient to drive the series regulator transistors. The emitter bias potential for mixer amplifier Q3 is established by the emitter follower. Transistor Q3 receives the error voltage input from either the constant voltage or constant current circuit via the OR-gate diode (CR3 or CR4) that is conducting at that time. Diode CR3 is forward biased, and CR4 reversed biased, during constant voltage operation. The reverse is true during constant current operation.

4-30 The RC network, composed of C5 and R30, is an equalizing network which provides for high frequency roll off in the loop gain response in order to stabilize the feedback loop. Emitter follower transistors Q4 and Q5 are the error amplifiers serving as the driver and predriver elements, respectively, for the series regulator. Transistor Q4, together with diode CR17, provides a low resistance discharge path for the output capacitance of the power supply during rapid down programming.

4-31 REFERENCE CIRCUIT

4-32 The reference circuit is a feedback power

supply similar to the main supply. It provides stable reference voltages which are used throughout the unit. The reference voltages are all derived from smoothed DC obtained from the full wave rectifier (CR22 and CR23) and filter capacitor C10. The +6.2 and -6.2 voltages, which are used in the constant voltage and current input circuits for comparison purposes, are developed across temperature compensated Zener diodes VR1 and VR2. Resistor R43 limits the current through the Zener diodes to establish an optimum bias level.

4-33 The regulating circuit consists of series regulating transistor Q9 and error amplifier Q8. Output voltage changes are detected by Q8 whose base is connected to the junction of a voltage divider (R41, R42) connected directly across the supply. Any error signals are amplified and inverted by Q8 and applied to the base of series transistor Q9. The series element then alters its conduction in the direction and by the amount necessary to maintain the voltage across VR1 and VR2 constant. Resistor R46, the emitter resistor for Q8, is connected in a manner which minimizes changes in the reference voltage caused by variations in the input line. Output capacitor C9 stabilizes the regulator loop.

4-34 METER CIRCUIT

4-35 The meter circuit provides continuous indications of output voltage or current on a single multiple range meter. The meter can be used either as a voltmeter or an ammeter depending upon the position of the METER switch S2 on the front panel of the supply. This switch also selects one of two meter ranges on each scale. The meter circuit consists basically of a selection circuit (switch S2 and associated voltage dividers), stable differential amplifier stages (Q11, Q12, and Q14), and the meter movement.

4-36 The selection circuit determines which voltage divider is connected to the differential amplifier input. When the METER section of S2 is in one of the voltage positions, the voltage across divider R59, R60, and R61 (connected across the output of the supply) is the input to the differential amplifier.

4-37 When S2 is in one of the current positions the voltage across divider R56, R57, and R58 is the input to the differential amplifier. Note that this divider is connected across the sampling resistor network. The amplified output of the differential amplifier is used to deflect the meter.

4-38 The differential amplifier is a stable device having a fixed gain of ten. Stage Q11B of the amplifier receives a negative voltage from the appli-

cable voltage divider when S2 is in one of the voltage positions while stage Q11A is connected to the +S (common) terminal. With S2 in a current position, stage Q11A receives a positive voltage from the applicable voltage divider while stage Q11B is connected to the +S terminal. The differential output of the amplifier is taken from the collectors of Q12 and Q14. Transistor Q15 is a constant current source which sets up the proper bias current for the amplifier. Potentiometer R63 permits zeroing of the meter.

4-39 The meter amplifier contains an inherent current limiting feature which protects the meter movement against overloads. For example, if METER switch S2 is placed in the low current range when the power supply is actually delivering a higher ampere output, the differential amplifiers are quickly driven into saturation limiting the current through the meter to a safe value.

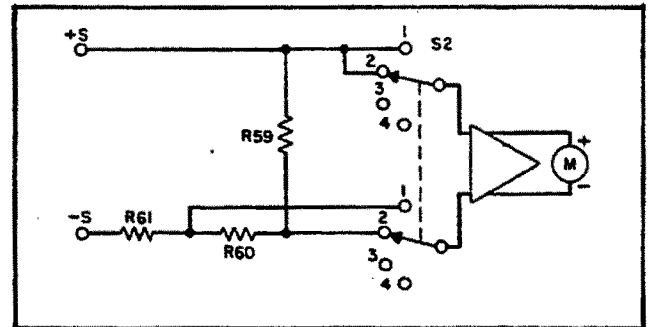

Figure 4-3. Voltmeter Connections, Simplified Schematic

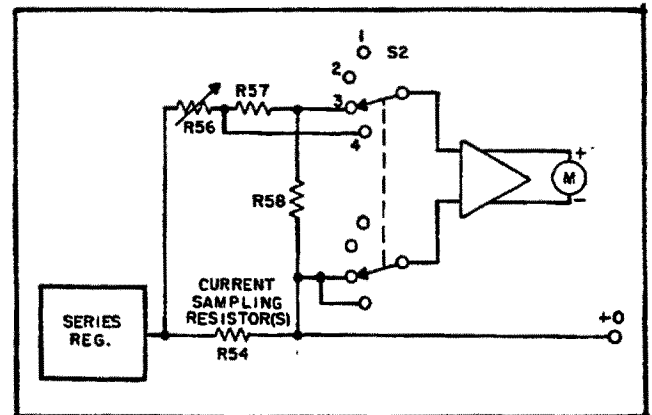

Figure 4-4. Ammeter Connections, Simplified Schematic

4-40 Figures 4-3 and 4-4 show the meter connections when the METER section of S2 is in the higher voltage and current range positions, respectively. For the sake of simplicity, some of the

actual circuit components are not shown on these drawings. With the METER switch in the higher voltage range, position 2, the voltage drop across R59 is the input to the meter amplifier and the meter indicates the output voltage across the +S and -S terminals. For low output voltages, S2 can be switched to the low voltage position (1) resulting in the application of a larger percentage of the output voltage (drop across R59 and R60) to the meter amplifier.

4-41 As illustrated in Figure 4-4 with the METER switch in the high current position (3) the voltage drop across R58 is applied to the meter amplifier and the meter indicates the output current which flows through the sampling resistor network. For low values of output current, the METER switch can be set to position 4 and the voltage drop across R57 and R58 is applied to the meter amplifier.

<http://www.ebaman.com>

SECTION V MAINTENANCE

5-1 INTRODUCTION

5-2 Upon receipt of the power supply, the performance check (Paragraph 5-10) should be made. This check is suitable for incoming inspection. If a fault is detected in the power supply while making the performance check or during normal operation, proceed to the troubleshooting procedures (Paragraph 5-41). After troubleshooting and repair (Paragraph 5-46), perform any necessary adjustments and calibrations (Paragraph 5-48). Before returning the power supply to normal operation, repeat the performance check to ensure that the fault has been properly corrected and that no other faults exist. Before doing any maintenance checks, turn on power supply, allow a half-hour warm-up, and read the general information regarding measurement techniques (Paragraph 5-3).

5-3 GENERAL MEASUREMENT TECHNIQUES

5-4 The measuring device must be connected across the sensing leads of the supply or as close to the output terminals as possible when measuring the output impedance, transient response, regulation, or ripple of the power supply in order to achieve valid measurements. A measurement made across the load includes the impedance of the leads to the load and such lead lengths can easily have an impedance several orders of magnitude greater than the supply impedance, thus invalidating the measurement.

5-5 The monitoring device should be connected to the +S and -S terminals (see Figure 3-2) or as shown in Figure 5-1. The performance characteristics should never be measured on the front terminals if the load is connected across the rear terminals. Note that when measurements are made at the front terminals, the monitoring leads are connected at A, not B, as shown in Figure 5-1. Failure to connect the measuring device at A will result in a measurement that includes the resistance of the leads between the output terminals and the point of connection.

5-6 For output current measurements, the current sampling resistor should be a four-terminal resis-

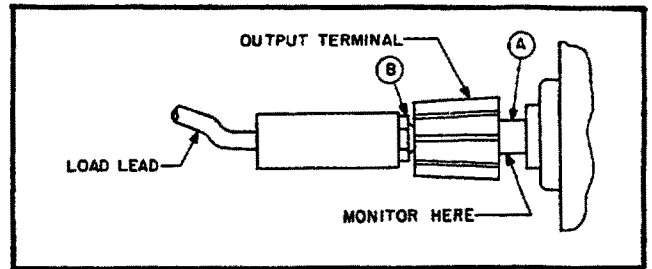

Figure 5-1. Front Panel Terminal Connections

tor. The four terminals are connected as shown in Figure 5-2. In addition, the resistor should be of the low noise, low temperature coefficient (less than 30ppm/°C) type and should be used at no more than 5% of its rated power so that its temperature rise will be minimized.

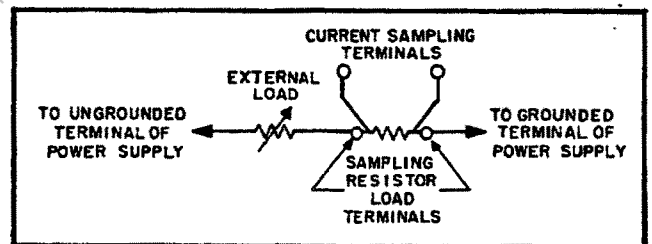

Figure 5-2. Output Current Measurement Technique

5-7 When using an oscilloscope, ground one terminal of the power supply and then ground the case of the oscilloscope to this same point. Make certain that the case is not also grounded by some other means (Power line). Connect both oscilloscope input leads to the power supply ground terminal and check that the oscilloscope is not exhibiting a ripple or transient due to ground loops, pickup, or other means.

5-8 TEST EQUIPMENT REQUIRED

5-9 Table 5-1 lists the test equipment required to perform the various procedures described in this Section.

Table 5-1. Test Equipment Required

TYPE	REQUIRED CHARACTERISTICS	USE	RECOMMENDED MODEL
Differential Voltmeter	Sensitivity: 1mV full scale (min.). Input impedance: 10 megohms (min.).	Measure DC voltages; calibration procedures	Ⓢ 3420 (See Note)
Variable Voltage Transformer	Range: 90-130 volts. Equipped with voltmeter accurate within 1 volt.	Vary AC input	---
AC Voltmeter	Accuracy: 2%. Sensitivity: 1mV full scale deflection (min.).	Measure AC voltages and ripple	Ⓢ 403B
Oscilloscope	Sensitivity: 100 μ V/cm. Differential input.	Display transient response waveforms	Ⓢ 140A plus 1400A plug-in. 1402A plug-in for spike measurements only.
Oscillator	Range: 5 Hz to 600 kHz. Accuracy: 2%. Output: 10Vrms.	Impedance checks	Ⓢ 200 CD
DC Voltmeter	Accuracy: 1%. Input resistance: 20,000 ohms/volt (min.).	Measure DC voltages	Ⓢ 412A
Repetitive Load Switch	Rate: 60 - 400 Hz, 2 μ sec rise and fall time.	Measure transient response	See Figure 5-8.
Resistive Loads	Values: See Paragraph 5-14 and Figure 5-4. \pm 5%, 75 watts.	Power supply load resis- tors	---
Current Sampling Resistor	6253A, 6284A: 0.33 Ω 6255A, 6289A: 0.66 Ω 6281A: 0.2 Ω 6294A: 1 Ω	Measure current; calibrate meter; cc ripple and noise	See Parts List R54 (R55)
Resistor	1K Ω \pm 1%, 2 watt non-inductive.	Measure impedance	---
Resistor	100 ohms, \pm 5%, 10 watt.	Measure impedance	---
Resistor	Value: See Paragraph 5-59. \pm 0.1%, 1/2 watt.	Calibrate programming current	---
Resistor	Value: See Paragraph 5-62. \pm 0.1% 1/2 watt.	Calibrate programming current	---
Capacitor	500 μ f, 50 wVdc.	Measure impedance	---
Decade Resistance Box	Range: 0-500K. Accuracy: 0.1% plus 1 ohm. Make-before-break contacts.	Measure programming coefficients	---

NOTE

A satisfactory substitute for a differential voltmeter is to arrange a reference voltage source and null detector as shown in Figure 5-3. The reference voltage source is adjusted so that the voltage difference between the supply being measured and the reference voltage will have the required resolution for the measurement being made. The voltage difference will be a function of the null detector that is used. Examples of satisfactory null detectors are: Ⓢ 419A null detector, a dc coupled oscilloscope utilizing differential input, or a 50mV meter movement with a 100 division scale. For the latter, a 2mV change in voltage will result in a meter deflection of four divisions.

CAUTION

Care must be exercised when using an electronic null detector in which one input terminal is grounded to avoid ground loops and circulating currents.

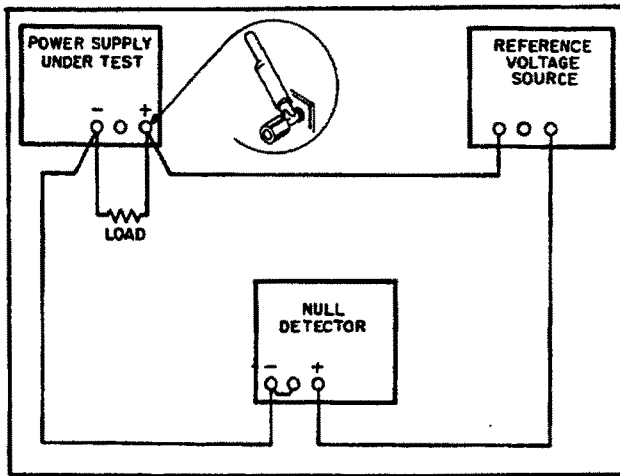

Figure 5-3. Differential Voltmeter Substitute, Test Setup

5-10 PERFORMANCE TEST

5-11. The following test can be used as an incoming inspection check and appropriate portions of the test can be repeated either to check the operation of the instrument after repairs or for periodic maintenance tests. The tests are performed using a 115Vac 60Hz, single phase input power source. If the correct result is not obtained for a particular check, do not adjust any controls; proceed to troubleshooting (Paragraph 5-41).

5-12 CONSTANT VOLTAGE TESTS

5-13 Rated Output and Meter Accuracy.

5-14 Voltage. Proceed as follows:

- Connect load resistor across rear output terminals of supply. Resistor value to be as follows:

Model	6253A	6255A	6281A	6284A	6289A	6294A
Resistance	6 Ω	26 Ω	1.5 Ω	6 Ω	26 Ω	60 Ω
- Connect differential voltmeter across +S and -S terminals of supply observing correct polarity.
- Set METER switch to highest voltage range and turn on supply.
- Adjust VOLTAGE control(s) until front panel meter indicates exactly the maximum rated output voltage.
- Differential voltmeter should indicate maximum rated output voltage within $\pm 2\%$.

5-15 Current. Proceed as follows:

- Connect test setup as shown in Figure 5-4 leaving switch S1 open.
- Turn CURRENT controls fully clockwise.
- Set METER switch to highest current range and turn on supply.
- Adjust VOLTAGE control(s) until front panel meter indicates exactly the maximum rated output current.
- Differential voltmeter should read 1.0 ± 0.02 Vdc.

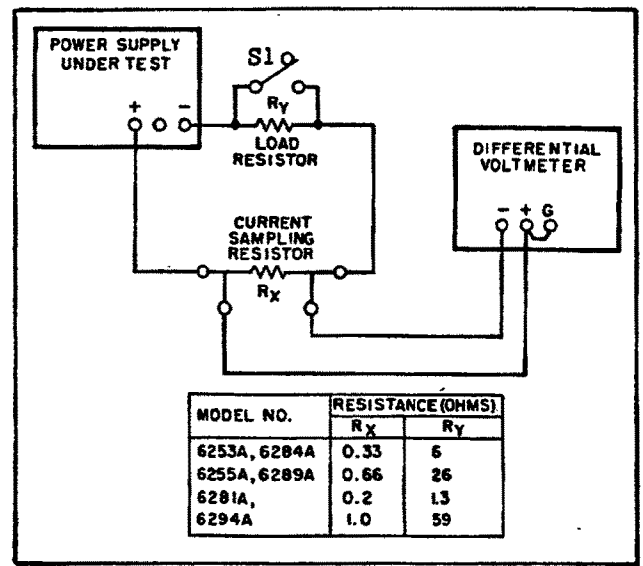

Figure 5-4. Output Current Test Setup

5-16. Load Regulation. To check constant voltage load regulation, proceed as follows:

- Connect test setup as shown in Figure 5-5.
- Turn CURRENT controls fully clockwise.
- Set METER switch to highest current range and turn on supply.
- Adjust VOLTAGE control(s) until front panel meter indicates exactly the maximum rated output voltage.
- Read and record voltage indicated on differential voltmeter.
- Disconnect load resistors.
- Reading on differential voltmeter should not vary from reading recorded in step by more than the following:

Model No.	6253A, 6284A	6255A, 6289A
Variation (mVdc)	± 6	± 6
Model No.	6281A	6294A
Variation (mVdc)	± 5	± 8

5-17 Line Regulation: To check the line regulation, proceed as follows:

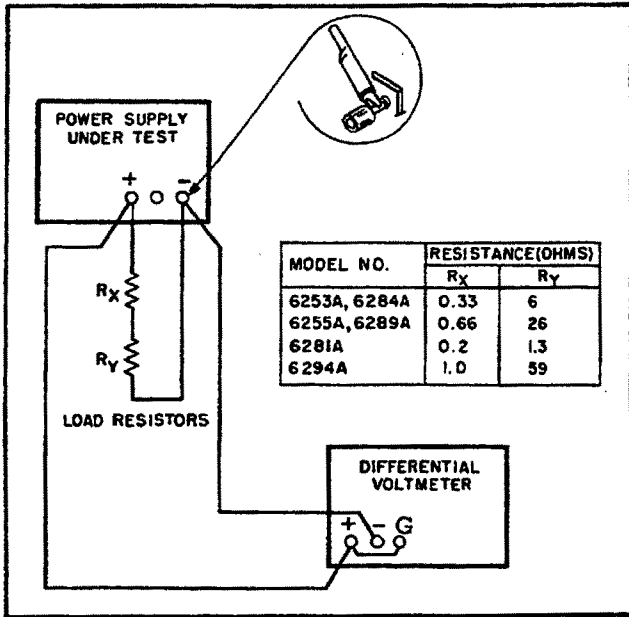

Figure 5-5. Load Regulation, Constant Voltage Test Setup

- Connect variable auto transformer between input power source and power supply power input.
- Turn CURRENT controls fully clockwise.
- Connect test setup shown in Figure 5-5.
- Adjust variable auto transformer for 105Vac input.
- Set METER switch to highest voltage range and turn on supply.
- Adjust VOLTAGE control(s) until front panel meter indicates exactly the maximum rated output voltage.
- Read and record voltage indicated on differential voltmeter.
- Adjust variable auto transformer for 125Vac input.
- Reading on differential voltmeter should not vary from reading recorded in step g by more than the following:

Model No.	6253A, 6284A	6255A, 6289A
Variation (mVdc)	±4	±6
Model No.	6281A	6294A
Variation (mVdc)	±2.75	±8

5-18 Ripple and Noise. Ripple and noise measurement can be made at any input AC line voltage combined with any DC output voltage and load current within rating.

5-19 The amount of ripple and noise that is present on the power supply output is measured either in terms of the RMS or (preferably) peak-to-peak value. The peak-to-peak measurement is particularly important for applications where noise spikes could be detrimental to a sensitive load, such as logic circuitry. The RMS measurement is not an ideal

representation of the noise, since fairly high output noise spikes of short duration could be present in the ripple and not appreciably increase the RMS value.

5-20 The technique used to measure high frequency noise or "spikes" on the output of a power supply is more critical than the low frequency ripple and noise measurement technique; therefore the former is discussed separately in Paragraph 5-28.

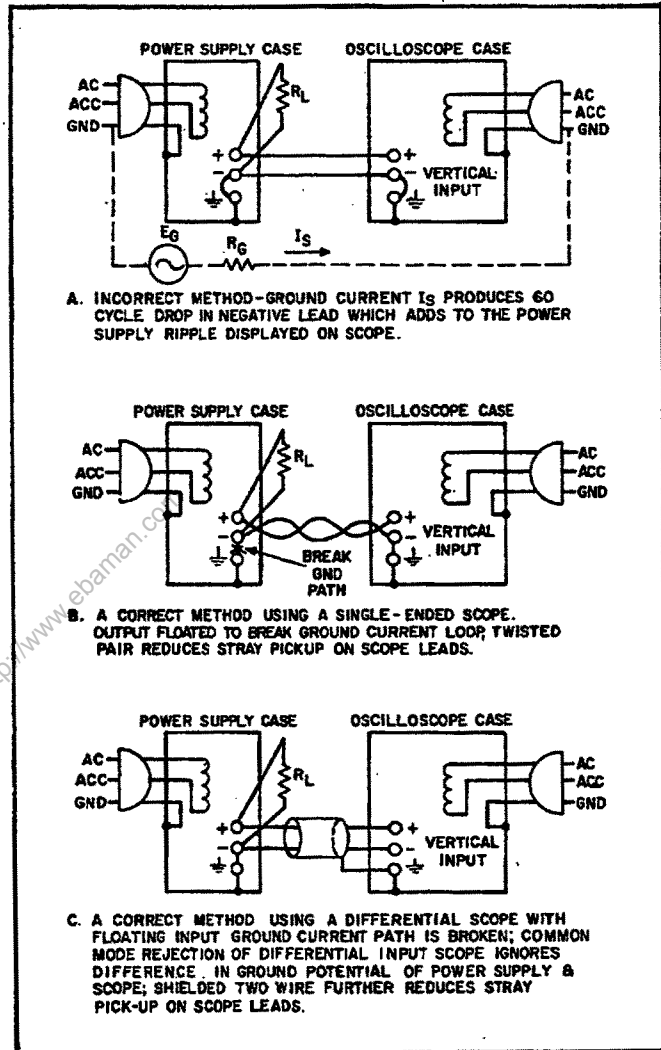

Figure 5-6. CV Ripple and Noise Test Setup

5-21 Ripple and Noise Measurements. Figure 5-6A shows an incorrect method of measuring p-p ripple. Note that a continuous ground loop exists from the third wire of the input power cord of the supply to the third wire of the input power cord of the oscilloscope via the grounded power supply case, the wire between the negative output terminal of the power supply and the vertical input of the scope, and the grounded scope case. Any ground current

circulating in this loop as a result of the difference in potential E_G between the two ground points causes an IR drop which is in series with the scope input. This IR drop, normally having a 60Hz line frequency fundamental, plus any pickup on the unshielded leads interconnecting the power supply and scope, appears on the face of the CRT. The magnitude of this resulting noise signal can easily be much greater than the true ripple developed between the plus and minus output terminals of the power supply, and can completely invalidate the measurement.

5-22 The same ground current and pickup problems can exist if an RMS voltmeter is substituted in place of the oscilloscope in Figure 5-6. However, the oscilloscope display, unlike the true RMS meter reading, tells the observer immediately whether the fundamental period of the signal displayed is 8.3 milliseconds (1/120 Hz) or 16.7 milliseconds (1/60 Hz). Since the fundamental ripple frequency present on the output of an AC supply is 120 Hz (due to full-wave rectification), an oscilloscope display showing a 120 Hz fundamental component is indicative of a "clean" measurement setup, while the presence of a 60 Hz fundamental usually means that an improved setup will result in a more accurate (and lower) value of measured ripple.

5-23 Figure 5-6B shows a correct method of measuring the output ripple of a constant voltage power supply using a single-ended scope. The ground loop path is broken by floating the supply output. Note that to ensure that no potential difference exists between the supply and the oscilloscope, it is recommended that whenever possible they both be plugged into the same AC power buss. If the same buss cannot be used, both AC grounds must be at earth ground potential.

5-24 Either a twisted pair or (preferably) a shielded two-wire cable should be used to connect the output terminals of the power supply to the vertical input terminals of the scope. When using a twisted pair, care must be taken that one of the two wires is connected to the grounded input terminal of the oscilloscope. When using shielded two-wire, it is essential for the shield to be connected to ground at one end only so that no ground current will flow through this shield, thus inducing a noise signal in the shielded leads.

5-25 To verify that the oscilloscope is not displaying ripple that is induced in the leads or picked up from the grounds, the (+) scope lead should be shorted to the (-) scope lead at the power supply terminals. The ripple value obtained when the leads are shorted should be subtracted from the actual ripple measurement.

5-26 In most cases, the single-ended scope method of Figure 5-6B will be adequate to eliminate non-real components of ripple and noise so that a satisfactory measurement may be obtained. However, in more stubborn cases it may be necessary to use a differential scope with floating input as shown in Figure 5-6C. If desired, two single conductor shielded cables may be substituted in place of the shielded two-wire cable with equal success. Because of its common mode rejection, a differential oscilloscope displays only the difference in signal between its two vertical input terminals, thus ignoring the effects of any common mode signal introduced because of the difference in the AC potential between the power supply case and scope case. Before using a differential input scope in this manner, however, it is imperative that the common mode rejection capability of the scope be verified by shorting together its two input leads at the power supply and observing the trace on the CRT. If this trace is a straight line, the scope is properly ignoring any common mode signal present. If this trace is not a straight line, then the scope is not rejecting the ground signal and must be realigned in accordance with the manufacturer's instructions until proper common mode rejection is attained.

5-27 To check the ripple and noise output, proceed as follows:

- a. Connect the oscilloscope or RMS voltmeter as shown in Figures 5-6B or 5-6C.
- b. Turn the CURRENT control fully clockwise and adjust VOLTAGE control until front panel meter indicates maximum rated output voltage.
- c. The observed ripple and noise should be less than 200 μ V RMS and 1mV p-p.

5-28 Noise Spike Measurement. When a high frequency spike measurement is being made, an instrument of sufficient bandwidth must be used; an oscilloscope with a bandwidth of 20 MHz or more is adequate. Measuring noise with an instrument that has insufficient bandwidth may conceal high frequency spikes detrimental to the load.

5-29 The test setups illustrated in Figures 5-6A and 5-6B are generally not acceptable for measuring spikes; a differential oscilloscope is necessary. Furthermore, the measurement concept of Figure 5-6C must be modified if accurate spike measurement is to be achieved:

1. As shown in Figure 5-7, two coax cables, must be substituted for the shielded two-wire cable.
2. Impedance matching resistors must be included to eliminate standing waves and cable ringing, and the capacitors must be connected to block the DC current path.

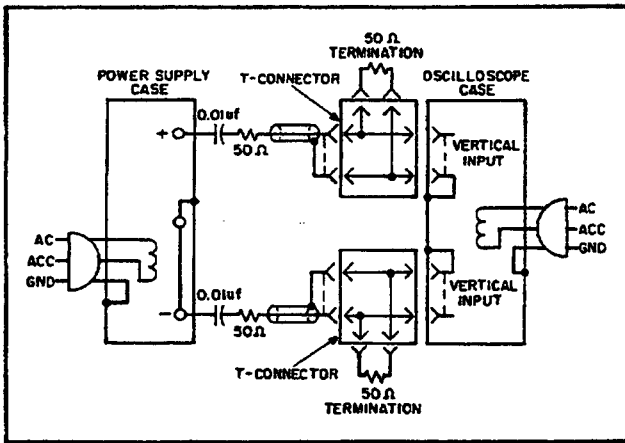

Figure 5-7. CV Noise Spike Test Setup

3. The length of the test leads outside the coax is critical and must be kept as short as possible; the blocking capacitor and the impedance matching resistor should be connected directly from the inner conductor of the cable to the power supply terminals.

4. Notice that the shields of the power supply end of the two coax cables are not connected to the power supply ground, since such a connection would give rise to a ground current path through the coax shield, resulting in an erroneous measurement.

5. The measured noise spike values must be doubled, since the impedance matching resistors constitute a 2-to-1 attenuator.

6. The noise spikes observed on the oscilloscope should be less than 0.5mV p-p.

5-30 The circuit of Figure 5-7 can also be used for the normal measurement of low frequency ripple and noise; simply remove the four terminating resistors and the blocking capacitors and substitute a higher gain vertical plug-in in place of the wide-band plug-in required for spike measurements. Notice that with these changes, Figure 5-7 becomes a two-cable version of Figure 5-6C.

5-31 Transient Recovery Time. To check the transient recovery time proceed as follows:

- Connect test setup shown in Figure 5-8.
- Turn CURRENT controls fully clockwise.
- Set METER switch to highest current range and turn on supply.
- Adjust VOLTAGE control(s) until front panel meter indicates exactly the maximum rated output voltage.
- Close line switch on repetitive load switch setup.
- Adjust 25K potentiometer until a stable display is obtained on oscilloscope. Waveform should be within the tolerances shown in Figure 5-9 (output should return to within 15mV of original value in less than 50 microseconds).

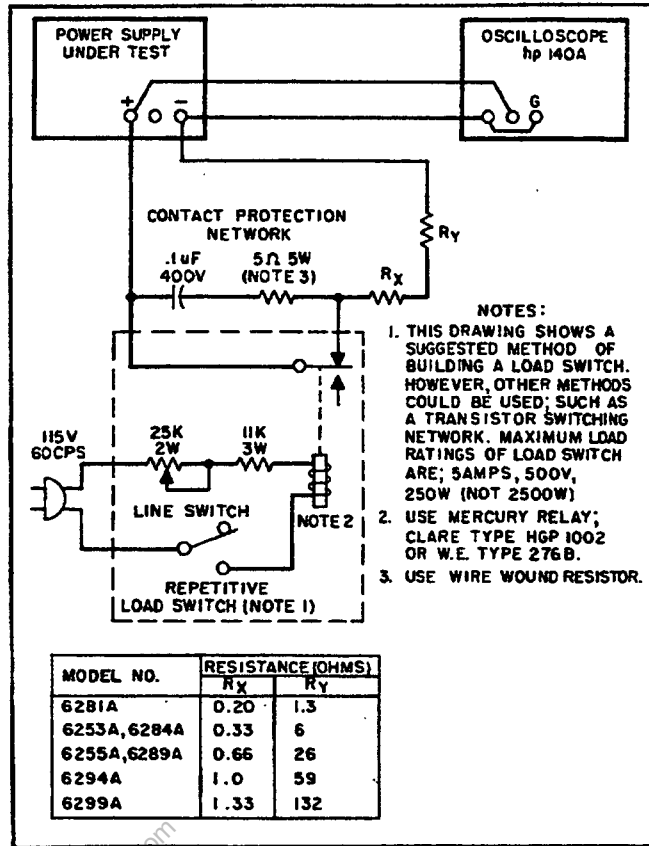

Figure 5-8. Transient Response, Test Setup

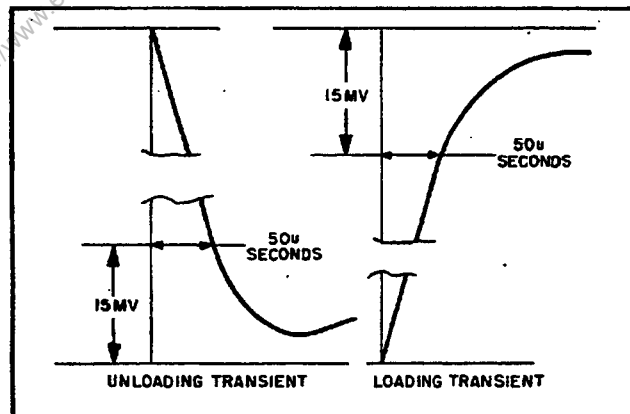

Figure 5-9. Transient Response, Waveforms

5-32 Programming Speed. This measurement is made by monitoring the output voltage with an oscilloscope while rapidly changing the remote programming resistance. For up-programming, the remote resistance is varied from zero ohms to the value that will produce maximum output voltage; and for down-programming, the remote resistance is varied from the value that will produce maximum output voltage to zero ohms. To check the up-programming speed, make the connections indicated in Figure 5-10; for down-programming, simply remove R_L.

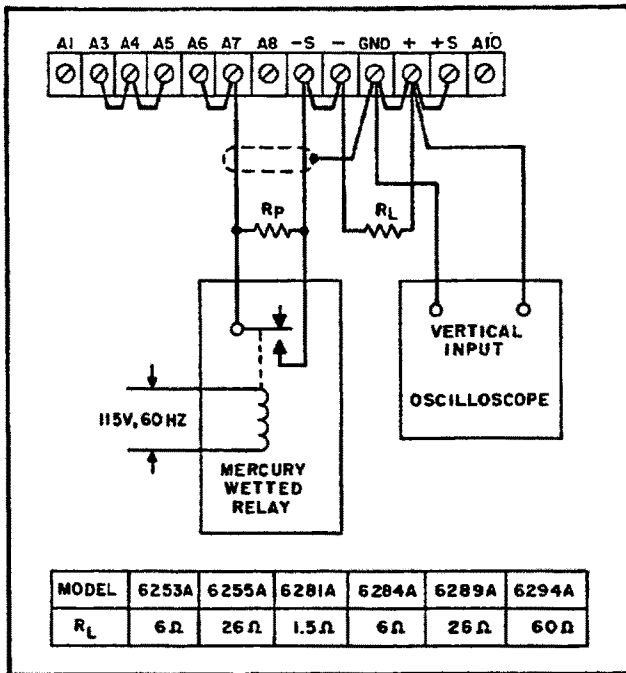

Figure 5-10. Constant Voltage Programming Speed, Test Setup

The load resistance is included for up-programming and removed for down-programming to present the worst possible conditions for the supply to reach the programmed voltage. Refer to Application Note 90, Power Supply Handbook for further details on remote programming speed. To check the programming speed, proceed as follows:

1. Restrap the rear barrier strip as indicated in Figure 5-10. Note that the jumper between +S and A10 is removed. This disconnects the output capacitor C20 to increase the programming speed. A minimum amount of output capacitance (C19) is permanently wired to the output and should not be removed, because the supply could oscillate under certain load conditions. The programming speed increases by a factor of from 10 to 100 when the output capacitor C20 is removed.

2. Connect the relay, oscilloscope, and programming resistor R_p as illustrated in Figure 5-10. Select the value of the programming resistor that will produce maximum output voltage of the supply. This value is obtained by multiplying the programming coefficient (200 ohms/volt, 300 ohms/volt for Model 6294A) by the maximum rated output voltage of the supply.

3. A mercury-wetted relay is employed to rapidly switch the programming resistance from zero to maximum at a 60 Hz rate. Other automatic switching devices can be used; however, a hand-operated switch connected across the programming resistor is not adequate, because the resulting one-shot displays are difficult to observe on most oscilloscopes.

4. The time (T) required for the output voltage to change from zero volts to maximum rated output or from maximum rated output to zero should be less than 10 milliseconds.

5-33 Output Impedance. To check the output impedance, proceed as follows:

- a. Connect test setup as shown in Figure 5-11.

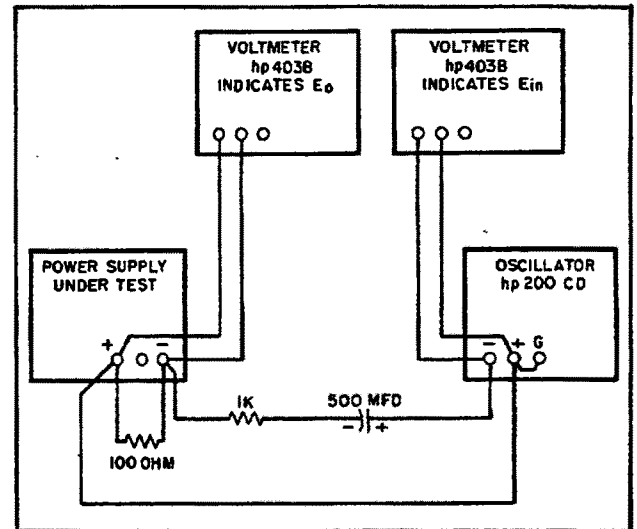

Figure 5-11. Output Impedance, Test Setup

- b. Set METER switch to highest voltage range and turn CURRENT controls fully clockwise, and turn on supply.

- c. Adjust VOLTAGE control(s) until front panel meter reads 20 volts.

- d. Set AMPLITUDE control on Oscillator to 10 volts (E_{in}), and FREQUENCY control to 1 kHz.

- e. Record voltage across output terminals of the power supply (E_o) as indicated on AC voltmeter.

- f. Calculate the output impedance by the following formula: $Z_{out} = (E_o R) / (E_{in} - E_o)$

E_o = rms voltage across power supply output terminals.

$R = 1000$.

$E_{in} = 10$ volts.

- g. The output impedance (Z_{out}) should be less than 0.01 ohm.

- h. Using formula of step f, calculate output impedance at frequencies of 10kHz, 100kHz, and 1MHz. Values should be less than 0.05 ohm, 0.5 ohm, and 5 ohms, respectively.

5-34 CONSTANT CURRENT TESTS

5-35 Load Regulation. To check the constant current load regulation, proceed as follows:

- a. Connect test setup as shown in Figure 5-4.
- b. Turn VOLTAGE control(s) fully clockwise.
- c. Set METER switch to highest current range

and turn on supply.

d. Adjust CURRENT control until front panel meter reads exactly the maximum rated output current.

e. Read and record voltage indicated on differential voltmeter.

f. Short out load resistor (R_L) by closing switch S_1 .

g. Reading on differential voltmeter should not vary from reading recorded in step e by more than the following:

Model No.	6253A, 6284A	6255A, 6289A
Variation (mVdc)	± 0.183	± 0.265

Model No.	6281A	6294A
Variation (mVdc)	± 0.5	± 0.35

5-36 Line Regulation. To check the line regulation proceed as follows:

a. Utilize test setup shown in Figure 5-4 leaving switch S_1 open throughout test.

b. Connect variable auto transformer between input power source and power supply power input.

c. Adjust auto transformer for 105Vac input.

d. Turn VOLTAGE control(s) fully clockwise.

e. Set METER switch to highest current range and turn on supply.

f. Adjust CURRENT controls until front panel meter reads exactly the maximum rated output current.

g. Read and record voltage indicated on differential voltmeter.

h. Adjust variable auto transformer for 125 Vac input.

i. Reading on differential voltmeter should not vary from reading recorded in step g by more than the following:

Model No.	6253A, 6284A	6255A, 6289A
Variation (mVdc)	± 0.183	± 0.265

Model No.	6281A	6294A
Variation (mVdc)	± 0.15	± 0.35

5-37 Ripple and Noise. Most of the instructions pertaining to the ground loop and pickup problems associated with constant voltage ripple and noise measurement also apply to the measurement of constant current ripple and noise. Figure 5-12 illustrates the most important precautions to be observed when measuring the ripple and noise of a constant current supply. The presence of a 120 cycle waveform on the oscilloscope is normally indicative of a correct measurement method. A waveshape having 60 Hz as its fundamental component is typically associated with an incorrect measurement setup.

5-38 Ripple and Noise Measurement. To check the ripple and noise, proceed as follows:

a. Connect the oscilloscope or RMS voltmeter as shown in Figures 5-12B or 5-12C.

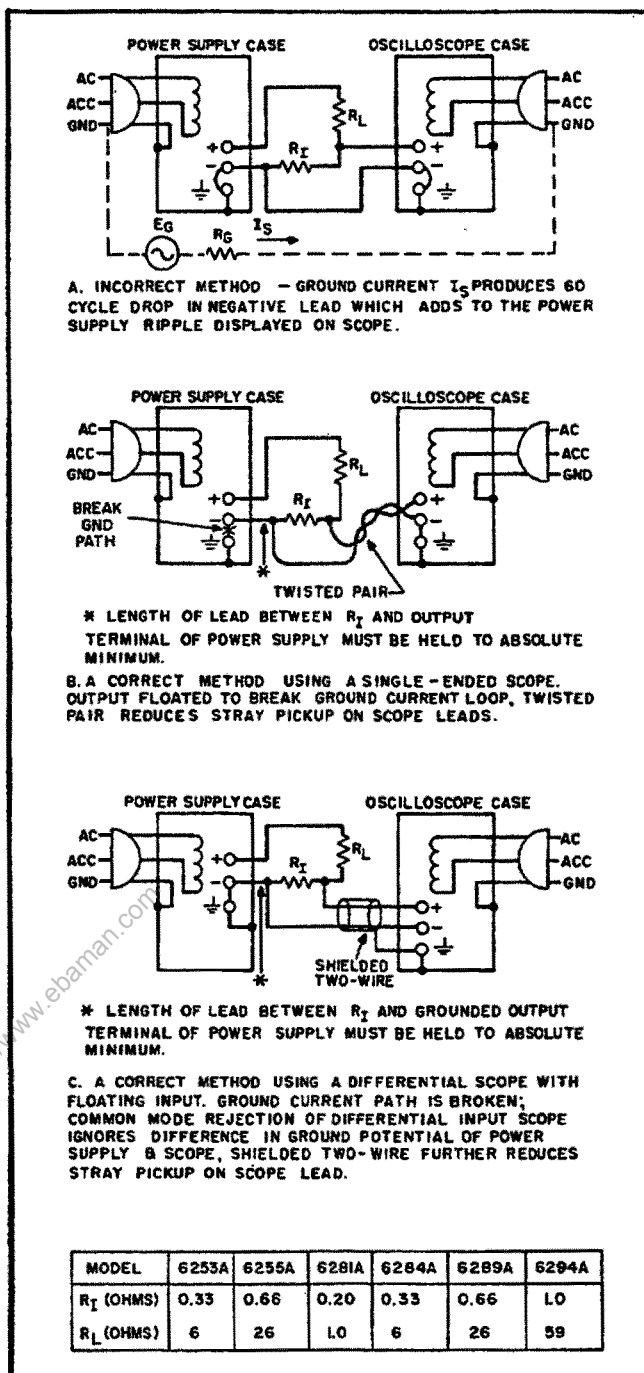

Figure 5-12. CC Ripple and Noise Test Setup

b. Rotate the VOLTAGE control fully cw.

c. Set METER switch to highest current range and turn on supply.

d. Adjust CURRENT control until front panel meter reads exactly the maximum rated output current.

e. The ripple and noise indication should be less than the following:

Model	6253A, 6284A	6255A, 6289A	6281A	6294A
mA rms	2	0.5	4	0.5

5-39 TROUBLESHOOTING

5-40 Components within Hewlett-Packard power supplies are conservatively operated to provide maximum reliability. In spite of this, parts within a supply may fail. Usually the instrument must be immediately repaired with a minimum of "down time" and a systematic approach as outlined in succeeding paragraphs can greatly simplify and speed up the repair.

5-41 TROUBLE ANALYSIS

5-42 General. Before attempting to troubleshoot this instrument, ensure that the fault is with the instrument and not with an associated circuit. The performance test (Paragraph 5-10) enables this to be determined without having to remove the instrument from the cabinet.

5-43 Once it is determined that the power supply is at fault, check for obvious troubles such as open fuse, a defective power cable, or an input power failure. Next, remove the top and bottom covers (each held by four retaining screws) and inspect for open connections, charred components, etc. If the trouble source cannot be detected by visual inspection, follow the detailed procedure outlined in succeeding paragraphs. Once the defective component has been located (by means of visual inspection or trouble analysis) correct it and re-conduct the performance test. If a component is replaced, refer to the repair and replacement and adjustment and calibration paragraphs in this section.

5-44 A good understanding of the principles of operation is a helpful aid in troubleshooting, and it

is recommended that the reader review Section IV of the manual before attempting to troubleshoot the unit in detail. Once the principles of operation are understood, logical application of this knowledge used in conjunction with the normal voltage readings shown on the schematic and the additional procedures given in the following paragraphs should suffice to isolate a fault to a component or small group of components. The normal voltages shown on the schematic are positioned adjacent to the applicable test points (identified by encircled numbers on the schematic and printed wiring boards).

5-45 Table 5-2 includes the symptoms and probable causes of many possible troubles. If either high or low output voltage is a symptom, there are two methods of isolating the fault. The first is a simplified procedure that involves only measuring voltages; the second is a more thorough approach requiring that transistor stages be opened or shorted. Both methods are described as follows:

1. First, the reference, bias, and filtered dc voltages as given in Table 5-3 should be checked. Then the voltage levels at critical points (base and collector) in the feedback loop should be measured and compared to the normal voltages given on the overall schematic diagram at the rear of the manual. This method of troubleshooting a feedback loop is not always conclusive; a better method is described in (2).

2. First, measure the reference, bias, and filtered dc voltages as given in Table 5-3. Then, drive each stage in the feedback loop into conduction or cutoff by either shorting or opening the previous stage as indicated in Tables 5-4 or 5-5.

Table 5-2. Common Troubles

Symptom	Probable Cause
Low output or no output voltage	Refer to Table 5-3, then 5-4.
High output voltage	Refer to Table 5-3, then 5-5.
High ripple	a. Check operating setup for ground—refer to Paragraph 5-18. b. If output floating, connect 1µf capacitor between output and ground. c. Check for excessive internal ripple; refer to Table 5-3. d. Ensure that supply is not in constant-current operation under loaded conditions. To prevent this condition turn CURRENT control fully clockwise. e. Check for low voltage across C14, C12, or C10.

Table 5-2. Common Troubles (Continued)

Symptom	Probable Cause
Poor line regulation	<ul style="list-style-type: none"> a. Improper measuring technique; refer to Paragraph 5-3. b. Check reference circuit voltages, Table 5-3. c. Check reference circuit adjustment, Paragraph 5-62.
Poor load regulation (Constant Voltage)	<ul style="list-style-type: none"> a. Improper measuring technique; refer to Paragraph 5-3. b. Check the regulation characteristics of Zener diode VR1 as follows: <ul style="list-style-type: none"> (1) Connect differential voltmeter across VR1 (2) Connect appropriate load resistor (R_L), given in Figure 5-4, across (+) and (-) output terminals (3) Perform steps b through f of Paragraph 5-16 (4) If the differential voltmeter reading varies by more than 0.5mV, replace VR1. c. Ensure that supply is not in constant-current operation under loaded conditions. To prevent this condition turn CURRENT control fully clockwise.
Poor load regulation (Constant Current)	<ul style="list-style-type: none"> a. Improper measuring technique; refer to Paragraph 5-3. b. Check the regulation characteristics of Zener diode VR2 as follows: <ul style="list-style-type: none"> (1) Connect differential voltmeter across VR2 (2) Connect appropriate load resistor (R_L), given in Figure 5-4, across (+) and (-) output terminals (3) Perform steps b through f of Paragraph 5-35 (4) If the differential voltmeter reading varies by more than 0.5mV, replace VR2. c. C19, C20, and CR34 leaky. d. Check clamp circuit, Q10, CR30, VR3, and CR32. e. Ensure that supply is not crossing over into constant voltage operation. To prevent this condition, load the supply and turn the VOLTAGE control fully clockwise.
Oscillates	<ul style="list-style-type: none"> a. Check C5 open. Adjustment of R30; refer to Paragraph 5-64. b. Check R21 and C3 in current input circuit.
Poor stability (Constant Voltage)	<ul style="list-style-type: none"> a. Check +6.2Vdc reference voltage (Table 5-3). b. Noisy programming resistor R10. c. CR1, CR2 leaky. d. Check R1, R12, R13, and C2 for noise or drift. e. Stage Q1 defective.
Poor stability (Constant Current)	<ul style="list-style-type: none"> a. Check -6.2Vdc reference voltage (Table 5-3). b. Noisy programming resistor R16. c. CR5, CR34, C19, C3 leaky. d. Check R18, R19, R20, R21, R54, and R55 for noise or drift. e. Stage Q2 defective.
Poor transient recovery	<ul style="list-style-type: none"> a. Check R30 and C5. Refer to adjustment procedure Paragraph 5-64.

Table 5-3. Reference, Bias, and filtered DC Troubleshooting

Meter Common	Meter Positive	Normal Vdc	Normal Ripple (P-P)	Probable Cause
31	+S	6.2	0.5mV	VR2
+S	33	6.2	0.5mV	VR1
+S	37	12.4	5mV	Q8, Q9
34	37	24	±.4V	C10, CR22, CR23, T1
41	23	4.4	20mV	VR4
41	38	28V(6253A)	3V	C12, CR24, CR25, T1
		53V(6255A)	1V	
		12V(6281A)	2V	
		28V(6284A)	3V	
		53V(6289A)	1V	
		80V(6294A)	1V	
- Out	27	38V(6253A)	0.4V	C14, C16, CR26, CR27, R49, T1
		62V(6255A)	0.6V	
		21V(6281A)	0.2V	
		38V(6284A)	0.4V	
		62V(6289A)	0.5V	
		90V(6294A)	0.8V	

Table 5-4. Low Output Voltage Troubleshooting

Step	Action	Response	Probable Cause
1	Turn the VOLTAGE control fully clockwise and disconnect the load		
2	To eliminate the constant current circuit as a cause of the malfunction, remove CR4 cathode or anode lead	a. Output increases b. Output remains low	a. Stage Q2 defective b. Reconnect CR4 and proceed to step 3
3	Check conduction of Q6 and Q7 by connecting a jumper between Q4 emitter (22) and base (18)	a. Output remains low b. Output increases	a. Q6, Q7, CR11 or associated parts defective b. Remove jumper and proceed to step 4
4	Check turnoff of Q4 by shorting Q5 emitter to base	a. Output remains low b. Output increases	a. Q4, CR17, R38 defective b. Remove jumper and proceed to step 5
5	Check turnoff of Q5 by shorting Q3 emitter to collector	a. Output remains low b. Output increases	a. Q5, R31 or associated components defective b. Remove short across Q3 and proceed to step 6

Table 5-4. Low Output Voltage Troubleshooting (Continued)

Step	Action	Response	Probable Cause
6	Check conduction of Q3 by shorting Q1A emitter to collector	a. Output remains low b. Output increases	a. Stage Q3 or Q16 defective b. Remove short and proceed to step 7
7	Remove CR32 anode or cathode lead	a. Output increases b. Output remains low	a. Voltage clamp circuit is defective b. Reconnect CR32. Stage Q1 defective. Check R10, C1 for short and R12, R13 for open.

Table 5-5. High Output Voltage Troubleshooting

Step	Action	Response	Probable Cause
1	Turn the VOLTAGE control to approximately mid-range and disconnect the load. If the output voltage should rise to an excessive value with the VOLTAGE control turned ccw, the control could be damaged.		
2	Check turnoff of Q6 and Q7 by shorting collector of Q5 to emitter of Q4	a. Output remains high b. Output decreases	a. Q6, Q7, CR11, R23, R27, R34 defective b. Remove short across Q4 and proceed to step 3
3	Check conduction of Q4 by shorting Q5 emitter to collector	a. Output remains high b. Output decreases	a. Q4, CR17, R38 defective b. Remove short across Q5 and proceed to step 4
4	Open Q3 collector lead Check conduction of Q5 by shorting R33	a. Output remains high b. Output decreases	a. Q5, R31 or associated components defective b. Remove short and proceed to step 5
5	Check turnoff of Q3 by shorting Q3 base to emitter	a. Output remains high b. Output decreases	a. Stage Q3 or Q17 defective b. Remove short and proceed to step 6
6	Remove CR32 anode or cathode.	a. Output decreases b. Output remains high	a. Voltage clamp circuit is defective b. Reconnect CR32 and proceed to step 7
7	On rear terminal board, short A6 to (-)	a. Output remains high b. Output decreases	a. Stage Q1 defective b. Remove short across terminals A6 and (-). Check R10 for open and R12, R13 for short.

Excessive heat or pressure can lift the copper strip from the board. Avoid damage by using a low power soldering iron (50 watts maximum) and following these instructions. Copper that lifts off the board should be cemented in place with a quick drying acetate base cement having good electrical insulating properties.

A break in the copper should be repaired by soldering a short length of tinned copper wire across the break.

Use only high quality rosin core solder when repairing etched circuit boards. NEVER USE PASTE FLUX. After soldering, clean off any excess flux and coat the repaired area with a high quality electrical varnish or lacquer.

When replacing components with multiple mounting pins such as tube sockets, electrolytic capacitors, and potentiometers, it will be necessary to lift each pin slightly, working around the components several times until it is free.

WARNING: If the specific instructions outlined in the steps below regarding etched circuit boards without eyelets are not followed, extensive damage to the etched circuit board will result.

1. Apply heat sparingly to lead of component to be replaced. If lead of component passes through an eyelet in the circuit board, apply heat on component side of board. If lead of component does not pass through an eyelet, apply heat to conductor side of board.

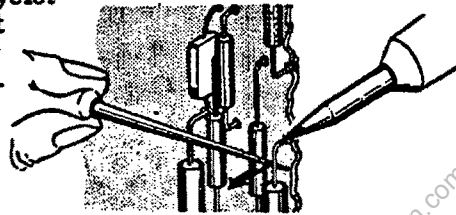

2. Reheat solder in vacant eyelet and quickly insert a small awl to clean inside of hole.

If hole does not have an eyelet, insert awl or a #57 drill from conductor side of board.

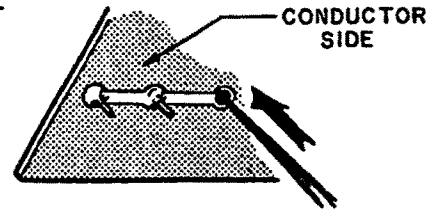

3. Bend clean tinned lead on new part and carefully insert through eyelets or holes in board.

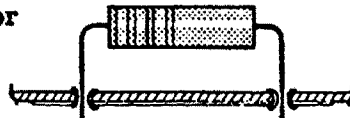

4. Hold part against board (avoid overheating) and solder leads.

Apply heat to component leads on correct side of board as explained in step 1.

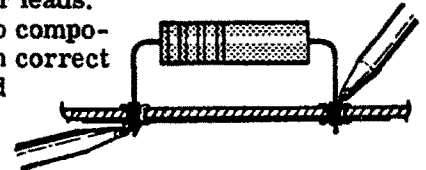

In the event that either the circuit board has been damaged or the conventional method is impractical, use method shown below. This is especially applicable for circuit boards without eyelets.

1. Clip lead as shown below.

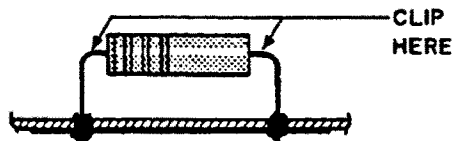

2. Bend protruding leads upward. Bend lead of new component around protruding lead. Apply solder using a pair of long nose pliers as a heat sink.

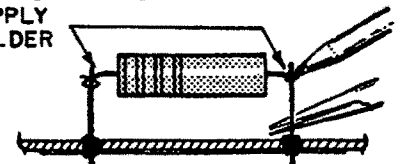

This procedure is used in the field only as an alternate means of repair. It is not used within the factory.

Figure 5-13. Servicing Printed Wiring Boards

5-46 REPAIR AND REPLACEMENT

5-47 Before servicing a printed wiring board, refer to Figure 5-13. Section VI of this manual contains a list of replaceable parts. Before replacing a semiconductor device, refer to Table 5-6 which lists the

special characteristics of selected semiconductors. If the device to be replaced is not listed in Table 5-6, the standard manufacturers part number listed in Section VI is applicable. After replacing a semiconductor device, refer to Table 5-7 for checks and adjustments that may be necessary.

Table 5-6. Selected Semiconductor Characteristics

Reference Designator	Characteristics	Stock No.	Suggested Replacement
Q1, 2, 11	Matched differential amplifier. NPN Si Planar. 70 (min.) hFE $I_C = 1$ ma. VCE = 5V. $I_{CO} 0.01\mu A @ V_{CBO} = 5V$.	1854-0229	2N2917 G. E.
Q6, 7(16)	NPN Power. hFE = 35 (min.) @ $I_C = 4A$, VCE = 4V.	1854-0228	2N3055 R. C. A.
CR1-5, 19, 20, 30, 32	Si. rectifier, 200ma, 200prv	1901-0033	1N485B Sylvania
VR3	Diode, zener, 4.22V, 400mW	1902-3070	1N749 Motorola
VR4, 5	Diode, zener, 4.3V, 1W	1902-0797	1N3824 Motorola

Table 5-7. Checks and Adjustments After Replacement of Semiconductor Devices

Reference	Function	Check	Adjust
Q1	Constant voltage differential amplifier	Constant voltage (CV) line and load regulation. Zero volt output.	R6 or R8
Q2	Constant current differential amplifier	Constant current (CC) line and load regulation. Zero current output.	R25 or R28
Q3, Q16	Mixer amplifier	CV/CC load regulation. CV transient response.	R30.
Q4, Q5	Error amplifiers and driver	CV/CC load regulation.	
Q6, Q7	Series regulator	CV/CC load regulation.	
Q8, Q9	Reference regulator	Reference circuit line regulation.	R46
Q10	Clamp circuit	CC load regulation.	
Q11-Q15	Meter circuit	Meter zero. Voltmeter/ammeter tracking.	R63, R72 R56
CR1, CR2	Limiting diodes	CV load regulation.	
CR3, CR4, CR5	OR-gate diodes and limiting diode	CV/CC load regulation.	

Table 5-7. Checks and Adjustments After Replacement of Semiconductor Devices (Continued)

Reference	Function	Check	Adjust
CR8-CR10	Forward bias regulator	Voltage across each diode 0.6 to 0.9 volts.	
CR22-CR27	Rectifier diodes	Voltage across appropriate filter capacitor.	
CR34	Protection diode	Output voltage	
VR1	Positive reference voltage	Positive reference voltage (+6.2V).	
VR2	Negative reference voltage	Negative reference voltage (-6.2V).	
VR4	Bias voltage	4.4V	

Table 5-8. Calibration and Adjustment Summary

Adjustment or Calibration	Paragraph	Control Device
Meter Zero	5-50	Pointer
Voltmeter Tracking	5-52	R63 and R72
Ammeter Tracking	5-54	R56
"Zero" Volt Output	5-57	R6 or R8
"Voltage" Programming Current	5-58	R13
"Zero" Current Output	5-60	R25 or R28

Adjustment or Calibration	Paragraph	Control Device
"Current" Programming Current	5-61	R19
Reference Circuit Line Voltage Adjustment	5-63	R46
Negative Reference Load Adjustment	5-64	Replace VR2
Positive Reference Load Adjustment	5-65	Replace VR1
Transient Response	5-66	R30

5-48 ADJUSTMENT AND CALIBRATION

5-49 Adjustment and calibration may be required after performance testing, troubleshooting, or repair and replacement. Perform only those adjustments that affect the operation of the faulty circuit and no others. Table 5-8 summarizes the adjustments and calibrations contained in the following paragraphs.

5-50 METER ZERO

5-51 The meter pointer must rest on the zero calibration mark on the meter scale when the instrument is at normal operating temperature, resting in its normal operating position, and the instrument is turned off. To zero-set the meter proceed as follows:

a. Turn on instrument and allow it to come up to normal operating temperature (about 20

minutes).

b. Turn the instrument off. Wait two minutes for power supply capacitors to discharge completely.

c. Rotate adjustment screw on front of meter clockwise until the meter pointer is to the left of zero and further clockwise rotation will move the pointer upscale towards zero.

d. Turn the adjustment screw clockwise until the pointer is exactly over the zero mark on the scale. If the screw is turned too far, repeat steps c and d.

e. Turn meter adjustment screw counterclockwise about 15 degrees to break contact between adjustment screw and pointer mounting yoke, but not far enough to move the pointer back downscale. If screw is turned too far, as shown by the needle moving, repeat the procedure. The meter is now zero-set for best accuracy and mechanical stability.

5-52 VOLTMETER TRACKING

5-53 To calibrate voltmeter tracking, proceed as follows:

- To electrically zero meter, set METER switch to highest current position and, with supply on and no load connected, adjust R63 until front panel meter reads zero.
- Connect differential voltmeter across supply, observing correct polarity.
- Set METER switch to highest voltage range and turn on supply. Adjust VOLTAGE control until differential voltmeter reads exactly the maximum rated output voltage.
- Adjust R72 until front panel meter also indicates maximum rated output voltage.

5-54 AMMETER TRACKING

5-55 To calibrate ammeter tracking proceed as follows:

- Connect test setup shown on Figure 5-4 leaving switch S1 open.
- Turn VOLTAGE control fully clockwise and set METER switch to highest current range.
- Turn on supply and adjust CURRENT controls until differential voltmeter reads 1.0Vdc.
- Adjust R56 until front panel meter indicates exactly the maximum rated output current.

5-56 CONSTANT VOLTAGE PROGRAMMING CURRENT

5-57 To calibrate the zero volt programming accuracy, proceed as follows:

- Connect differential voltmeter between +S and -S terminals.
- Short out voltage controls by connecting jumper between terminals A6 and -S.
- Rotate CURRENT controls fully clockwise and turn on supply.
- Observe reading on differential voltmeter.
- If it is more positive than 0 volts, shunt resistor R6 with decade resistance box.
- Adjust decade resistance until differential voltmeter reads zero, then shunt R6 with resistance value equal to that of the decade resistance.
- If reading of step d is more negative than 0 volts, shunt resistor R8 with the decade resistance box.
- Adjust decade resistance until differential voltmeter reads zero then shunt R8 with resistance value equal to that of the decade box.

5-58 To calibrate the constant voltage programming current, proceed as follows:

- Connect a 0.1%, $\frac{1}{2}$ watt resistor between terminals -S and A6 on rear barrier strip. Resistor value to be as follows:

<u>Model</u>	6253A, 6284A	6255A, 6289A	6281A	6294A
<u>Resistance</u>	4K Ω	8K Ω	1.5K Ω	18K Ω

- Disconnect jumper between A6 and A8 (leaving A6 and A7 jumpered) on rear terminal barrier strip.

c. Connect a decade resistance in place of R13.

d. Connect a differential voltmeter between +S and -S and turn on supply.

e. Adjust decade resistance box so that differential voltmeter indicates maximum rated output voltage within the following tolerances:

<u>Model No.</u>	6253A, 6284A	6255A, 6289A
<u>Tolerance (Vdc)</u>	± 0.4	± 0.8

<u>Model No.</u>	6281A	6294A
<u>Tolerance (Vdc)</u>	± 0.15	± 1.2

f. Replace decade resistance with resistor of appropriate value in R13 position.

5-59 CONSTANT CURRENT PROGRAMMING CURRENT

5-60 To calibrate the zero current programming accuracy, proceed as follows:

- Connect differential voltmeter between +S and -S terminals.
- Short out current controls by connecting jumper between terminals A1 and A5.
- Rotate VOLTAGE control(s) fully clockwise and turn on supply.
- Observe reading on differential voltmeter.
- If it is more positive than 0 volts, shunt resistor R25 with a decade resistance box.
- Adjust decade resistance until differential voltmeter reads zero, then shunt R25 with resistance value equal to that of decade resistance.
- If reading of step d is more negative than 0 volts, shunt resistor R28 with decade resistance.
- Adjust decade resistance until differential voltmeter reads zero, then shunt R28 with resistance value equal to that of decade box.

5-61 To calibrate the constant current programming current, proceed as follows:

- Connect power supply as shown in Figure 5-4.

b. Remove strap between A3 and A4 (leaving A4 and A5 jumpered).

c. Connect a 0.1%, $\frac{1}{2}$ watt resistor between A1 and A5. Resistor value to be as follows:

<u>Model No.</u>	6253A, 6284A	6255A, 6289A
<u>Resistance</u>	1.5K Ω	750 Ω

<u>Model No.</u>	6281A	6294A
<u>Resistance</u>	1K Ω	1K Ω

d. Connect decade resistance box in place of R19.

e. Set METER switch to highest current range and turn on supply.

f. Adjust the decade resistance so that the differential voltmeter indicates 1.0 ± 0.01 Vdc.

g. Replace decade resistance with appropriate value resistor in R19 position.

5-62 REFERENCE CIRCUIT ADJUSTMENTS

5-63 Line Regulation. To adjust the line regulation capabilities of the instrument proceed as follows:

- a. Connect the differential voltmeter between +S (common) and 33 (positive).
- b. Connect variable voltage transformer between supply and input power source.
- c. Adjust line to 105 Vac.
- d. Connect decade resistance in place of R46.
- e. Turn on supply and adjust VOLTAGE control(s) for maximum rated output voltage.
- f. Adjust decade resistance so that voltage indicated by differential voltmeter does not change more than the following as input line voltage is varied from 105 to 125Vac:

<u>Model No.</u>	6253A, 6284A	6255A, 6289A
Variation (mVdc)	0.95	0.81
<u>Model No.</u>	6281A	6294A
Variation (mVdc)	1.24	0.75

g. Replace decade resistance with appropriate value resistor in R46 position.

5-64 CONSTANT VOLTAGE TRANSIENT RESPONSE

5-65 To adjust the transient response, proceed as follows:

- a. Connect test setup as shown in Figure 5-8.
- b. Repeat steps a through e as outlined in Paragraph 5-31.
- c. Adjust R30 so that the transient response is as shown in Figure 5-9.

<http://www.ebaman.com>

SECTION VI REPLACEABLE PARTS

6-1 INTRODUCTION

6-2 This section contains information for ordering replacement parts. Table 6-4 lists parts in alpha-numeric order by reference designators and provides the following information:

- a. Reference Designators. Refer to Table 6-1.
- b. Description. Refer to Table 6-2 for abbreviations.
- c. Total Quantity (TQ). Given only the first time the part number is listed except in instruments containing many sub-modular assemblies, in which case the TQ appears the first time the part number is listed in each assembly.
- d. Manufacturer's Part Number or Type.
- e. Manufacturer's Federal Supply Code Number. Refer to Table 6-3 for manufacturer's name and address.
- f. Hewlett-Packard Part Number.
- g. Recommended Spare Parts Quantity (RS) for complete maintenance of one instrument during one year of isolated service.
- h. Parts not identified by a reference designator are listed at the end of Table 6-4 under Mechanical and/or Miscellaneous. The former consists of parts belonging to and grouped by individual assemblies; the latter consists of all parts not immediately associated with an assembly.

6-3 ORDERING INFORMATION

6-4 To order a replacement part, address order or inquiry to your local Hewlett-Packard sales office (see lists at rear of this manual for addresses). Specify the following information for each part: Model, complete serial number, and any Option or special modification (J) numbers of the instrument; Hewlett-Packard part number; circuit reference designator; and description. To order a part not listed in Table 6-4, give a complete description of the part, its function, and its location.

Table 6-1. Reference Designators

A = assembly	E = miscellaneous
B = blower (fan)	electronic part
C = capacitor	F = fuse
CB = circuit breaker	J = jack, jumper
CR = diode	K = relay
DS = device, signaling (lamp)	L = inductor
	M = meter

Table 6-1. Reference Designators (Continued)

P = plug	V = vacuum tube, neon bulb, photocell, etc.
Q = transistor	
R = resistor	VR = zener diode
S = switch	X = socket
T = transformer	Z = integrated circuit or network
TB = terminal block	
TS = thermal switch	

Table 6-2. Description Abbreviations

A = ampere	mfr = manufacturer
ac = alternating current	mod. = modular or modified
assy. = assembly	mtg = mounting
bd = board	n = nano = 10^{-9}
bkt = bracket	NC = normally closed
°C = degree Centigrade	NO = normally open
cd = card	NP = nickel-plated
coef = coefficient	Ω = ohm
comp = composition	obd = order by description
CRT = cathode-ray tube	OD = outside diameter
CT = center-tapped	p = pico = 10^{-12}
dc = direct current	P.C. = printed circuit
DPDT = double pole, double throw	pot. = potentiometer
DPST = double pole, single throw	p-p = peak-to-peak
elect = electrolytic	ppm = parts per million
encap = encapsulated	pvr = peak reverse voltage
F = farad	rect = rectifier
°F = degree Fahrenheit	rms = root mean square
fxd = fixed	Si = silicon
Ge = germanium	SPDT = single pole, double throw
H = Henry	SPST = single pole, single throw
Hz = Hertz	SS = small signal
IC = integrated circuit	T = slow-blow
ID = inside diameter	tan. = tantalum
incnd = incandescent	Ti = titanium
k = kilo = 10^3	V = volt
m = milli = 10^{-3}	var = variable
M = mega = 10^6	ww = wirewound
μ = micro = 10^{-6}	W = Watt
met. = metal	

Table 6-3. Code List of Manufacturers

CODE NO.	MANUFACTURER	ADDRESS	CODE NO.	MANUFACTURER	ADDRESS
00629	EBY Sales Co., Inc.	Jamaica, N. Y.	07138	Westinghouse Electric Corp.	
00656	Aerovox Corp.	New Bedford, Mass.		Electronic Tube Div.	Elmira, N. Y.
00853	Sangamo Electric Co.		07263	Fairchild Camera and Instrument Corp.	Mountain View, Calif.
	S. Carolina Div.	Pickens, S. C.		Semiconductor Div.	
01121	Allen Bradley Co.	Milwaukee, Wis.	07387	Bircher Corp., The	Los Angeles, Calif.
01255	Litton Industries, Inc.	Beverly Hills, Calif.	07397	Sylvania Electric Prod. Inc.	
				Sylvania Electronic Systems	Mountain View, Calif.
01281	TRW Semiconductors, Inc.	Lawndale, Calif.		Western Div.	
01295	Texas Instruments, Inc.		07716	IRC Div. of TRW Inc.	Burlington Plant Burlington, Iowa
	Semiconductor-Components Div.		07910	Continental Device Corp.	Hawthorne, Calif.
		Dallas, Texas	07933	Raytheon Co. Components Div.	
01686	RCL Electronics, Inc.	Manchester, N. H.		Semiconductor Operation	Mountain View, Calif.
01930	Amerock Corp.	Rockford, Ill.	08484	Breeze Corporations, Inc.	Union, N. J.
02107	Sparta Mfg. Co.	Dover, Ohio	08530	Reliance Mica Corp.	Brooklyn, N. Y.
02114	Ferroxcube Corp.	Saugerties, N. Y.	08717	Sloan Company, The	Sun Valley, Calif.
02606	Penwal Laboratories	Morton Grove, Ill.	08730	Vemaline Products Co. Inc.	Wyckoff, N. J.
02660	Amphenol Corp.	Broadview, Ill.	08806	General Elect. Co. Minia- ture Lamp Dept.	Cleveland, Ohio
02735	Radio Corp. of America, Solid State and Receiving Tube Div.	Somerville, N. J.	08863	Nylomatic Corp.	Norrisville, Pa.
03508	G. E. Semiconductor Products Dept.	Syracuse, N. Y.	08919	RCH Supply Co.	Vernon, Calif.
03797	Eldema Corp.	Compton, Calif.	09021	Airco Speer Electronic Components	Bradford, Pa.
03877	Transitron Electronic Corp.	Wakefield, Mass.	09182	*Hewlett-Packard Co. New Jersey Div.	Rockaway, N. J.
03888	Pyrofilm Resistor Co. Inc.	Cedar Knolls, N. J.	09213	General Elect. Co. Semiconductor Prod. Dept.	Buffalo, N. Y.
04009	Arrow, Hart and Hegeman Electric Co.	Hartford, Conn.	09214	General Elect. Co. Semiconductor Prod. Dept.	Auburn, N. Y.
04072	ADC Electronics, Inc.	Harbor City, Calif.	09353	C & K Components Inc.	Newton, Mass.
04213	Caddell & Burns Mfg. Co. Inc.	Mineola, N. Y.	09922	Burndy Corp.	Norwalk, Conn.
04404	*Hewlett-Packard Co. Palo Alto Div.	Palo Alto, Calif.	11115	Wagner Electric Corp.	
04713	Motorola Semiconductor Prod. Inc.	Phoenix, Arizona		Tung-Sol Div.	Bloomfield, N. J.
05277	Westinghouse Electric Corp.		11236	CTS of Berne, Inc.	Berne, Ind.
	Semiconductor Dept.	Youngwood, Pa.	11237	Chicago Telephone of Cal. Inc.	So. Pasadena, Calif.
05347	Ultronix, Inc.	Grand Junction, Colo.	11502	IRC Div. of TRW Inc.	Boone Plant Boone, N. C.
05820	Wakefield Engr. Inc.	Wakefield, Mass.	11711	General Instrument Corp	
06001	General Elect. Co. Electronic Capacitor & Battery Dept.	Irmo, S. C.		Rectifier Div.	Newark, N. J.
06004	Bassik Div. Stewart-Warner Corp.	Bridgeport, Conn.	12136	Philadelphia Handle Co. Inc.	Camden, N. J.
06486	IRC Div. of TRW Inc.		12615	U. S. Terminals, Inc.	Cincinnati, Ohio
	Semiconductor Plant	Lynn, Mass.	12617	Hamlin Inc.	Lake Mills, Wisconsin
06540	Amatom Electronic Hardware Co. Inc.	New Rochelle, N. Y.	12697	Clarostat Mfg. Co. Inc.	Dover, N. H.
06555	Beede Electrical Instrument Co.	Penacook, N. H.	13103	Thermalloy Co.	Dallas, Texas
06666	General Devices Co. Inc.	Indianapolis, Ind.	14493	*Hewlett-Packard Co. Loveland Div.	Loveland, Colo.
06751	Semcor Div. Components, Inc.	Phoenix, Arizona	14655	Cornell-Dubilier Electronics Div.	
06776	Robinson Nugent, Inc.	New Albany, Ind.		Federal Pacific Electric Co.	Newark, N. J.
06812	Torrington Mfg. Co., West Div.	Van Nuys, Calif.	14936	General Instrument Corp. Semicon- ductor Prod. Group	Hicksville, N. Y.
07137	Transistor Electronics Corp.	Minneapolis, Minn.	15801	Fenwal Elect.	Framingham, Mass.
			16299	Corning Glass Works, Electronic Components Div.	Raleigh, N. C.

*Use Code 28480 assigned to Hewlett-Packard Co., Palo Alto, California

Table 6-3. Code List of Manufacturers (Continued)

CODE NO.	MANUFACTURER	ADDRESS
16758	Delco Radio Div. of General Motors Corp.	Kokomo, Ind.
17545	Atlantic Semiconductors, Inc.	Asbury Park, N. J.
17803	Fairchild Camera and Instrument Corp Semiconductor Div. Transducer Plant	Mountain View, Calif.
17870	Daven Div. Thomas A. Edison Industries McGraw-Edison Co.	Orange, N. J.
18324	Signetics Corp.	Sunnyvale, Calif.
19315	Bendix Corp. The Navigation and Control Div.	Teterboro, N. J.
19701	Electra/Midland Corp.	Mineral Wells, Texas
21520	Fansteel Metallurgical Corp.	No. Chicago, Ill.
22229	Union Carbide Corp. Electronics Div.	Mountain View, Calif.
22753	UID Electronics Corp.	Hollywood, Fla.
23936	Pamotor, Inc.	Pampa, Texas
24446	General Electric Co.	Schenectady, N. Y.
24455	General Electric Co. Lamp Div. of Con- sumer Prod. Group	Nela Park, Cleveland, Ohio
24655	General Radio Co.	West Concord, Mass.
24681	LTV Electrosystems Inc Memcor/Com- ponents Operations	Huntington, Ind.
26982	Dynacool Mfg. Co. Inc.	Saugerties, N. Y.
27014	National Semiconductor Corp.	Santa Clara, Calif.
28480	Hewlett-Packard Co.	Palo Alto, Calif.
28520	Heyman Mfg. Co.	Kenilworth, N. J.
28875	IMC Magnetics Corp.	New Hampshire Div. Rochester, N. H.
31514	SAE Advance Packaging, Inc.	Santa Ana, Calif.
31827	Budwig Mfg. Co.	Ramona, Calif.
33173	G. E. Co. Tube Dept.	Owensboro, Ky.
35434	Lectrohm, Inc.	Chicago, Ill.
37942	P. R. Mallory & Co. Inc.	Indianapolis, Ind.
42190	Muter Co.	Chicago, Ill.
43334	New Departure-Hyatt Bearings Div. General Motors Corp.	Sandusky, Ohio
44655	Ohmite Manufacturing Co.	Skokie, Ill.
46384	Penn Engr. and Mfg. Corp.	Doylestown, Pa.
47904	Polaroid Corp.	Cambridge, Mass.
49956	Raytheon Co.	Lexington, Mass.
55026	Simpson Electric Co. Div. of American Gage and Machine Co.	Chicago, Ill.
56289	Sprague Electric Co.	North Adams, Mass.
58474	Superior Electric Co.	Bristol, Conn.
58849	Syntron Div. of FMC Corp.	Homer City, Pa.
59730	Thomas and Betts Co.	Philadelphia, Pa.
61637	Union Carbide Corp.	New York, N. Y.
63743	Ward Leonard Electric Co.	Mt. Vernon, N. Y.

CODE NO.	MANUFACTURER	ADDRESS
70563	Amperite Co. Inc.	Union City, N. J.
70901	Beemer Engrg. Co.	Fort Washington, Pa.
70903	Belden Corp.	Chicago, Ill.
71218	Bud Radio, Inc.	Willoughby, Ohio
71279	Cambridge Thermionic Corp.	Cambridge, Mass.
71400	Bussmann Mfg. Div. of McGraw & Edison Co.	St. Louis, Mo.
71450	CTS Corp.	Elkhart, Ind.
71468	I. T. T. Cannon Electric Inc.	Los Angeles, Calif.
71590	Globe-Union Inc.	Milwaukee, Wis.
71700	General Cable Corp. Cornish Wire Co. Div.	Williamstown, Mass.
71707	Coto Coil Co. Inc.	Providence, R. I.
71744	Chicago Miniature Lamp Works	Chicago, Ill.
71785	Cinch Mfg. Co. and Howard B. Jones Div.	Chicago, Ill.
71984	Dow Corning Corp.	Midland, Mich.
72136	Electro Motive Mfg. Co. Inc.	Willimantic, Conn.
72619	Dialight Corp.	Brooklyn, N. Y.
72699	General Instrument Corp.	Newark, N. J.
72765	Drake Mfg. Co.	Harwood Heights, Ill.
72962	Elastic Stop Nut Div. of Amerace Esna Corp.	Union, N. J.
72982	Erie Technological Products Inc.	Erie, Pa.
73096	Hart Mfg. Co.	Hartford, Conn.
73138	Beckman Instruments Inc.	Fullerton, Calif.
73168	Penwal, Inc.	Ashland, Mass.
73293	Hughes Aircraft Co. Electron Dynamics Div.	Torrance, Calif.
73445	Amperex Electronic Corp.	Hicksville, N. Y.
73506	Bradley Semiconductor Corp.	New Haven, Conn.
73559	Carling Electric, Inc.	Hartford, Conn.
73734	Federal Screw Products, Inc.	Chicago, Ill.
74193	Heinemann Electric Co.	Trenton, N. J.
74545	Hubbell Harvey Inc.	Bridgeport, Conn.
74868	Amphenol Corp. Amphenol RF Div.	Danbury, Conn.
74970	E. F. Johnson Co.	Waseca, Minn.
75042	IRC Div. of TRW, Inc.	Philadelphia, Pa.
75183	*Howard B. Jones Div. of Cinch Mfg. Corp.	New York, N. Y.
75376	Kurz and Kasch, Inc.	Dayton, Ohio
75382	Kilka Electric Corp.	Mt. Vernon, N. Y.
75915	Littlefuse, Inc.	Des Plaines, Ill.
76381	Minnesota Mining and Mfg. Co.	St. Paul, Minn.
76385	Minor Rubber Co. Inc.	Bloomfield, N. J.
76487	James Millen Mfg. Co. Inc.	Malden, Mass.
76493	J. W. Miller Co.	Compton, Calif.

*Use Code 71785 assigned to Cinch Mfg. Co., Chicago, Ill.

Table 6-3. Code List of Manufacturers (Continued)

CODE NO.	MANUFACTURER	ADDRESS
76530	Cinch	City of Industry, Calif.
76854	Oak Mfg. Co. Div. of Oak	Electro/Netics Corp. Crystal Lake, Ill.
77068	Bendix Corp., Electro-dynamics Div.	No. Hollywood, Calif.
77122	Palnut Co.	Mountainside, N. J.
77147	Patton-MacGuyer Co.	Providence, R. I.
77221	Phaostron Instrument and Electronic Co.	South Pasadena, Calif.
77252	Philadelphia Steel and Wire Corp.	Philadelphia, Pa.
77342	American Machine and Foundry Co.	Potter and Brumfield Div. Princeton, Ind.
77630	TRW Electronic Components Div.	Camden, N. J.
77764	Resistance Products Co.	Harrisburg, Pa.
78189	Illinois Tool Works Inc. Shakeproof Div.	Elgin, Ill.
78452	Everlock Chicago, Inc.	Chicago, Ill.
78488	Stackpole Carbon Co.	St. Marys, Pa.
78526	Stanwyck Winding Div. San Fernando	Electric Mfg. Co. Inc. Newburgh, N. Y.
78553	Tinnerman Products, Inc.	Cleveland, Ohio
78584	Stewart Stamping Corp.	Yonkers, N. Y.
79136	Waldes Kohinoor, Inc.	L. I. C., N. Y.
79307	Whitehead Metals Inc.	New York, N. Y.
79727	Continental-Wirt Electronics Corp.	Philadelphia, Pa.
79963	Zierick Mfg. Co.	Mt. Kisco, N. Y.
80031	Mepco Div. of Sessions Clock Co.	Morristown, N. J.
80294	Bourms, Inc.	Riverside, Calif.
81042	Howard Industries Div. of Msl Ind. Inc.	Racine, Wisc.
81073	Grayhill, Inc.	La Grange, Ill.
81483	International Rectifier Corp.	El Segundo, Calif.
81751	Columbus Electronics Corp.	Yonkers, N. Y.
82099	Goodyear Sundries & Mechanical Co. Inc.	New York, N. Y.
82142	Airco Speer Electronic Components	Du Bois, Pa.
82219	Sylvania Electric Products Inc.	Electronic Tube Div. Receiving Tube Operations Emporium, Pa.
82389	Switchcraft, Inc.	Chicago, Ill.
82647	Metals and Controls Inc. Control Products Group	Attleboro, Mass.
82866	Research Products Corp.	Madison, Wis.
82877	Rotron Inc.	Woodstock, N. Y.
82893	Vector Electronic Co.	Glendale, Calif.
83058	Carr Fastener Co.	Cambridge, Mass.
83186	Victory Engineering Corp.	Springfield, N. J.
83298	Bendix Corp. Electric Power Div.	Eatontown, N. J.
83330	Herman H. Smith, Inc.	Brooklyn, N. Y.
83385	Central Screw Co.	Chicago, Ill.
83501	Gavitt Wire and Cable Div. of Amerace Esna Corp.	Brookfield, Mass.

CODE NO.	MANUFACTURER	ADDRESS
83508	Grant Pulley and Hardware Co.	West Nyack, N. Y.
83594	Burroughs Corp. Electronic Components Div.	Plainfield, N. J.
83835	U. S. Radium Corp.	Morristown, N. J.
83877	Yardeny Laboratories, Inc.	New York, N. Y.
84171	Arco Electronics, Inc.	Great Neck, N. Y.
84411	TRW Capacitor Div.	Ogallala, Neb.
86684	RCA Corp. Electronic Components	Harrison, N. J.
86838	Rummel Fibre Co.	Newark, N. J.
87034	Marco & Oak Industries a Div. of Oak Electro/netics Corp.	Anaheim, Calif.
87216	Philco Corp. Lansdale Div.	Lansdale, Pa.
87585	Stockwell Rubber Co. Inc.	Philadelphia, Pa.
87929	Tower-Olschan Corp.	Bridgeport, Conn.
88140	Cutler-Hammer Inc. Power Distribution and Control Div. Lincoln Plant	Lincoln, Ill.
88245	Litton Precision Products Inc, USECO Div. Litton Industries	Van Nuys, Calif.
90634	Gulton Industries Inc.	Metuchen, N. J.
90763	United-Car Inc.	Chicago, Ill.
91345	Miller Dial and Nameplate Co.	El Monte, Calif.
91418	Radio Materials Co.	Chicago, Ill.
91506	Augat, Inc.	Attleboro, Mass.
91637	Dale Electronics, Inc.	Columbus, Neb.
91662	Elco Corp.	Willow Grove, Pa.
91929	Honeywell Inc. Div. Micro Switch	Freeport, Ill.
92825	Whitso, Inc.	Schiller Pk., Ill.
93332	Sylvania Electric Prod. Inc. Semi-conductor Prod. Div.	Woburn, Mass.
93410	Essex Wire Corp. Stemco Controls Div.	Mansfield, Ohio
94144	Raytheon Co. Components Div.	Ind. Components Oper. Quincy, Mass.
94154	Wagner Electric Corp.	Tung-Sol Div. Livingston, N. J.
94222	Southco Inc.	Lester, Pa.
95263	Leecraft Mfg. Co. Inc.	L. I. C., N. Y.
95354	Method Mfg. Co.	Rolling Meadows, Ill.
95712	Bendix Corp. Microwave Devices Div.	Franklin, Ind.
95987	Weckesser Co. Inc.	Chicago, Ill.
96791	Amphenol Corp. Amphenol Controls Div.	Janesville, Wis.
97464	Industrial Retaining Ring Co.	Irvington, N. J.
97702	IMC Magnetics Corp. Eastern Div.	Westbury, N. Y.
98291	Sealectro Corp.	Mamaroneck, N. Y.
98410	ETC Inc.	Cleveland, Ohio
98978	International Electronic Research Corp.	Burbank, Calif.
99934	Renbrandt, Inc.	Boston, Mass.

Reference Designator	Description	Quantity	Mfr. Part # or Type	Mfr.	Mfr. Code	Stock No.	RS
NOTE: ALL ELECTRICAL COMPONENTS HAVE DUPLICATED QUANTITIES EXCEPT THOSE MARKED WITH AN *							
C1	fxd, elect 4.7 μ f 50vdc	2	150D475X9050B2	Sprague	56289	0180-1731	1
C2, 18	fxd, film .01 μ f 200vdc	4	192P10392	Sprague	56289	0160-0161	1
C3	fxd, film 0.1 μ f 200vdc	2	192P10492	Sprague	56289	0160-0168	1
C4,7,8,11, 13,15,17	NOT ASSIGNED	-	-	-	-	-	-
C5	fxd, film .001 μ f 200vdc	2	192P10292	Sprague	56289	0160-0153	1
C6	fxd, elect 20 μ f 15vdc	2	30D206G0158B4	Sprague	56289	0180-0300	1
C9	fxd, elect 4.7 μ f 35vdc	2		HLAB	09182	0180-0100	1
C10	fxd, elect 100 μ f 50vdc	2		HLAB	09182	0180-1852	1
C12, 20	fxd, elect 490 μ f 75vdc	4	D38618	HLAB	09182	0180-1888	1
C14	fxd, elect 1600 μ f 70vdc	2		HLAB	09182	0180-1895	1
C16	fxd, ceramic .05 μ f 500vdc	2	33C17A	Sprague	56289	0150-0052	1
C19	fxd, elect 15 μ f 50vdc	2	150D156X0050R2	Sprague	56289	0180-1834	1
CR1-5, 19, 20, 30, 32	Rect. si. 200ma 200prv 250mw	18		HLAB	09182	1901-0033	8
CR6-10, 12-16, 21, 28, 29, 31, 33	NOT ASSIGNED	-	-	-	-	-	-
CR11, 18, 34	Rect. si. 3A 200prv	6	MR 1032B	Motorola	04713	1901-0416	6
CR17, 22-27	Rect. si. 900ma 200prv	14	1N5059	G. E.	03508	1901-0327	7
DS1	Lamp, neon part of si, ass'y.	Ref		HLAB	09182	2140-0244	1
F1	*Fuse Cartridge 4A @ 250V 3AG 1	1	312002	Littlefuse	75915	2110-0055	5
Q1, 2, 11	SS NPN diff. amp. si.	6		HLAB	09182	1854-0229	6
Q3, 5, 8, 10, 12, 14, 15	SS PNP si.	14	2N2907A	Sprague	56289	1853-0099	7
Q4	Power PNP si.	2	MJ 2268	Motorola	04713	1853-0063	2
Q6, 7	Power NPN si.	4		HLAB	09182	1854-0225	4
Q9, 16	SS NPN si.	4	4JX16A1014	G. E.	03508	1854-0071	4
Q13	NOT ASSIGNED	-	-	-	-	-	-
R1	fxd, ww 1K Ω \pm 5% 3w	2	242E1025	Sprague	56289	0813-0001	1
R2, 22, 23, 86	fxd, met. film 6.2K Ω \pm 1% 1/8w	8	Type CEA T-O	I. R. C.	07716	0698-5087	2
R3	fxd, met. film 15K Ω \pm 1% 1/8w	2	Type CEA T-O	I. R. C.	07716	0757-0446	1
R4, 64, 65	fxd, met. film 20K Ω \pm 1% 1/8w	6	Type CEA T-O	I. R. C.	07716	0757-0449	2
R5, 26, 29, 76, 77	fxd, met. film 1.5K Ω \pm 1% 1/8w	10	Type CEA T-O	I. R. C.	07716	0757-0427	2
R6, 25	fxd, comp 360K Ω \pm 5% 1/2w	4	EB-3645	A. B.	01121	0686-3645	1
R7	fxd, met. film 61.9K Ω \pm 1% 1/8w	2	Type CEA T-O	I. R. C.	07716	0757-0460	1
R8, 28	fxd, comp 560K Ω \pm 5% 1/2w	4	EB-5645	A. B.	01121	0686-5645	1
R9, 11, 17, 27, 32, 37, 48; 55, 78	NOT ASSIGNED	-	-	-	-	-	-
R10	var. ww DUAL 10K-100 Ω	2		HLAB	09182	2100-0997	1
R12	fxd, ww 1.3K Ω \pm 5% 3w	2	242E1325	Sprague	56289	0811-1803	1
R13, 19	fxd, comp SLECTED \pm 5%	4	Type EB	A. B.	01121		1
R14	fxd, comp 3.3K Ω \pm 5% 1/2w	2	EB-0335	A. B.	01121	0686-0335	1
R15	fxd, comp 330K Ω \pm 5% 1/2w	2	EB-3345	A. B.	01121	0686-3345	1
R16	var. ww DUAL 900 Ω -10 Ω	2		HLAB	09182	2100-0994	1

Reference Designator	Description	Quantity	Mfr. Part # or Type	Mfr.	Mfr. Code	Stock No.	RS
R18	fxd, ww 5K Ω \pm 5% 3w	2	242E5025	Sprague	56289	0811-2138	1
R20	fxd, met. film 1K Ω \pm 1% $\frac{1}{4}$ w	2	Type CEB T-O	I. R. C.	07716	0757-0338	1
R21	fxd, comp 39 Ω \pm 5% $\frac{1}{2}$ w	2	EB-3905	A. B.	01121	0686-3905	1
R24	fxd, met. film 4.75K Ω \pm 1% 1/8w	2	Type CEA T-O	I. R. C.	07716	0757-0437	1
R30	var. ww 5K Ω (Modify)	2	Type 110-F4	C. T. S.	11236	2100-1824	1
R31	fxd, comp 1K Ω \pm 5% $\frac{1}{2}$ w	2	EB-1025	A. B.	01121	0686-1025	1
R33, 38	fxd, comp 10K Ω \pm 5% $\frac{1}{2}$ w	4	EB-1035	A. B.	01121	0686-1035	1
R34	fxd, comp 160 Ω \pm 5% $\frac{1}{2}$ w	2	EB-1615	A. B.	01121	0686-1615	1
R35	fxd, comp 200 Ω \pm 5% $\frac{1}{2}$ w	2	EB-2015	A. B.	01121	0686-2015	1
R36	fxd, ww 500 Ω \pm 5% 10w	2		HLAB	09182	0811-1909	1
R39	fxd, met. film 1.21K Ω \pm 1% 1/8w	2	Type CEA T-O	I. R. C.	07716	0757-0274	1
R40, 57, 60, 62	fxd, met. film 900 Ω \pm 1% 1/8w.	8	Type CEA T-O	I. R. C.	07716	0757-1099	2
R41	fxd, comp 12K Ω \pm 5% $\frac{1}{2}$ w	2	EB-1235	A. B.	01121	0686-1235	1
R42	fxd, comp 6.8K Ω \pm 5% $\frac{1}{2}$ w	2	EB-6825	A. B.	01121	0686-6825	1
R43	fxd, met. film 422 Ω \pm 1% $\frac{1}{4}$ w	2	Type CEB T-O	I. R. C.	07716	0698-4590	1
R44	fxd, comp 47K Ω \pm 5% $\frac{1}{2}$ w	2	EB-4735	A. B.	01121	0686-4735	1
R45	fxd, comp 5.1K Ω \pm 5% $\frac{1}{2}$ w	2	EB-5125	A. B.	01121	0686-5125	1
R46	fxd, comp 100K Ω \pm 5% $\frac{1}{2}$ w	2	EB-1045	A. B.	01121	0686-1045	1
R47	fxd, comp 470 Ω \pm 5% $\frac{1}{2}$ w	2	EB-4715	A. B.	01121	0686-4715	1
R49	fxd, ww 900 Ω \pm 5% 15w	2		HLAB	09182	0811-0957	1
R50	fxd, comp 10 Ω \pm 5% $\frac{1}{2}$ w	2	EB-1005	A. B.	01121	0686-1005	1
R51	fxd, comp 30K Ω \pm 5%	2	EB-3035	A. B.	01121	0686-3035	1
R52	fxd, comp 22K Ω \pm 5% $\frac{1}{2}$ w	2	EB-2235	A. B.	01121	0686-2235	1
R53	fxd, comp 3K Ω \pm 5% $\frac{1}{2}$ w	2	EB-3025	A. B.	01121	0686-3025	1
R54	fxd, ww 0.66 Ω C. T. \pm 5% 20w	2		HLAB	09182	0811-1818	1
R56	var. ww 1K Ω (Modify)	2	Type 110-F4	C. T. S.	11236	2100-0391	1
R58, 59	fxd, met. film 100 Ω \pm 1% 1/8w	4	Type CEA T-O	I. R. C.	07716	0757-0401	1
R61	fxd, met. film 47.5K Ω \pm 1% 1/8w	2	Type CEA T-O	I. R. C.	07716	0757-0457	1
R66, 67	fxd, met. film 3.40K Ω \pm 1% $\frac{1}{4}$ w	4	Type CEB T-O	I. R. C.	07716	0698-4642	1
R68, 69	fxd, met. film 365 Ω \pm 1% $\frac{1}{4}$ w	4	Type CEB T-O	I. R. C.	07716	0757-0723	1
R70, 71, 75, 85	fxd, met. film 3K Ω \pm 1% 1/8w	8	Type CEA T-O	I. R. C.	07716	0757-1093	2
R72	var. ww 250 Ω (Modify)	2	Type 110-F4	C. T. S.	11236	2100-0439	1
R73	fxd, met. film 750 Ω \pm 1% 1/8w	2	Type CEA T-O	I. R. C.	07716	0757-0420	1
R74	fxd, met. film 9.09K Ω \pm 1% 1/8w	2	Type CEA T-O	I. R. C.	07716	0757-0288	1
R80	*fxd, comp 33K Ω \pm 5% $\frac{1}{2}$ w	1	EB-3335	A. B.	01121	0686-3335	1
R81-83	fxd, ww 120 Ω \pm 5% 75w	6	Type 6BR-37	H. H.	73978	0811-1971	2
S1	*Switch-pilot lite (red) ON/OFF SPDT	1	54-61681 26 AIH	Oak	87034	3101-0100	1
S2	Switch, meter	2		HLAB	09182	3100-1910	1
T1	Power transformer	2		HLAB	09182	9100-1838	1
VR1, 2	Diode, zener 6.2V	4	1N821	N. A. Elect.	06486	1902-0761	4
VR3	Diode, zener 4.22V 400MW	2		HLAB	09182	1902-3070	2
VR4, 5	Diode, zener 4.3V 1w	4		HLAB	09182	1902-0797	4
	Outrigger chassis	1	C-1	HLAB	09182	5000-6090	
	P. C. Board bracket	1	B-1	HLAB	09182	5000-6088	
	Transformer bracket - right	1	C-5950-5271-1	HLAB	09182	5000-6087	
	Transformer bracket - left	1	C-5950-5271-1	HLAB	09182	5000-6183	
	Front panel	1		HLAB	09182	06255-60001	
	Cover	2	D-1	HLAB	09182	5000-6089	
	Outrigger cover	1	C-1	HLAB	09182	5000-6091	
	Angle guard	2	B-5950-5221-1	HLAB	09182	5020-5540	

Reference Designator	Description	Quantity	Mfr. Part # or Type	Mfr.	Mfr. Code	Stock No.	RS
	P. C. Board assembly (includes components)	2		HLAB	09182	06255-60021	
	Printed circuit board (blank)	2		HLAB	09182	5020-5598	
	Chassis assembly - right	1	D-5950-5249-1	HLAB	09182	5060-6129	
	Chassis assembly - left	1	D-5950-5249-1	HLAB	09182	5060-6130	
	Sink assembly - heat	1	A-5950-5233-1	HLAB	09182	5606-6128	
	5 Way binding post (maroon)	2		HLAB	09182	1510-0040	1
	5 Way binding post (black)	4	DF21BC	Superior	58474	1510-0039	1
	Cable clamp $\frac{1}{4}$ I. D.	4	T4-4	Whitehead	79307	1400-0330	1
	Line cord plug PH151 $7\frac{1}{2}$ ft.	1	KH-4096	Beldon	70903	8120-0050	1
	Spacer - captive	4		HLAB	09182	0380-0742	1
	Strain relief bushing	1	SR-5P-1	Heyco	28520	0400-0013	1
	Knob 17/64 insert pointer	4		HLAB	09182	0370-0101	1
	Knob 3/16 insert	4		HLAB	09182	0370-0179	1
	Knob $\frac{1}{4}$ insert pointer	2		HLAB	09182	0370-0084	1
	Barrier strip	2		HLAB	09182	0360-1234	1
	Jumper	16	422-13-11-013	Cinch	71785	0360-1143	4
	Rubber bumper	4	MB 50	Stockwell	87575	0403-0088	1
	Fuseholder assembly	1	342014	Littlefuse	75915	1400-0084	1
	Mica insulator	4	734	Reliance	08530	0340-0174	4
	Meter $2\frac{1}{4}$ " size DUAL SCALE 0-50V 0-1.8A	2		HLAB	09182	1120-1139	1
	Bezel 1/6 MOD	2		HLAB	09182	4040-0295	1
	Spring	4		HLAB	09182	1460-0720	2
	Spacer $\frac{1}{4}$ HEX brass NI. PL.	4	# 6 x $\frac{1}{4}$ LG.	HLAB	09182	0380-0716	2
	Fastener	11	C8091-632-24B	Tinnerman	89032	0510-0275	3
	Captive nut	16	CLA 632-2	Pem. Eng.	46384	0590-0393	4
	Captive nut	4	CLA 832-2	Pem. Eng.	46384	0590-0395	1
	Insulator - transistor pin	8		HLAB	09182	0340-0166	6
	Insulator	8		HLAB	09182	0340-0168	6
	Rubber bumper	4	40-72	Stockwell	87575	0403-0086	1
	Rubber bumper black duro hard 55/60	2	3066	Stockwell	87575	0403-0085	1
OPTION 07: 10-Turn Voltage Control							
R10	var. ww 10K Ω \pm 5% 10-Turn Knob, R10, Black	2		HLAB	09182	2100-1866	1
		2		HLAB	09182	0370-0137	1
OPTION 08: 10-Turn Current Control							
R16	var. ww 1K Ω \pm 5% 10-Turn Knob, R16, Black	2		HLAB	09182	2100-1864	1
		2		HLAB	09182	0370-0137	1
OPTION 09: 10-Turn Voltage and Current Controls							
R10	var. ww 10K Ω \pm 5% 10-Turn	2		HLAB	09182	2100-1866	1
R16	var. ww 1K Ω \pm 5% 10-Turn	2		HLAB	09182	2100-1864	1
	Knob, R10 & R16, Black	4		HLAB	09182	0370-0137	1
OPTION 10: Chassis Slides							
	Slides	1	CTS-120-E6	Gen. Devices	06666	1490-0870	1
	Spacer	2		HLAB	09182	06253-00001	1

Reference Designator	Description	Quantity	Mfr. Part # or Type	Mfr.	Mfr. Code	Part No.	RS
<p style="text-align: center;">OPTION 11: Overvoltage Protection Crowbar</p> <p style="text-align: center;">See Appendix A for Parts List</p>							
<p style="text-align: center;">OPTION 13: 3-Digit Decadial Voltage Control</p>							
R10	var. ww 10K Ω \pm 5% 10-Turn Decadial	2		HLAB	09182	2100-1866	1
		2		HLAB	09182	1140-1120	1
<p style="text-align: center;">OPTION 14: 3-Digit Decadial Current Control</p>							
R16	var. ww 1K Ω \pm 5% 10-Turn Decadial	2		HLAB	09182	2100-1864	1
		2		HLAB	09182	1140-0020	1
<p style="text-align: center;">OPTION 28: 230Vac \pm10% Input</p>							
F1	Fuse 1A 250V	2	312.001	Littlefuse	75915	2110-0001	10

APPENDIX A
Option 11, Overvoltage Protection "Crowbar"

DESCRIPTION:

This option is installed in DC Power Supplies, 6253A, 6255A, 6281A, 6284A, 6289A, 6294A, and 6299A and tested at the factory. It consists of a printed circuit board, screwdriver-type front panel potentiometer, and six wires that are soldered to the main power supply board.

The crowbar monitors the output voltage of the power supply and fires an SCR that effectively shorts the output when it exceeds the preset trip voltage. The trip voltage is determined by the setting of the CROWBAR ADJUST control on the front panel. The trip voltage range is as follows:

Model	6253A	6255A	6281A	6284A	6289A	6294A	6299A
Trip Voltage Range	2.5-23V	2.5-44V	2.5-10V	2.5-23V	2.5-44V	2.5-65V	30-106V

To prevent transients from falsely tripping the crowbar, the trip voltage must be set higher than the power supply output voltage by the following margin: 4% of the output voltage plus 2V. The margin represents the minimum crowbar trip setting for a given output voltage; the trip voltage can always be set higher than this margin.

OPERATION:

1. Turn the CROWBAR ADJUST fully clockwise to set the trip voltage to maximum.
2. Set the power supply VOLTAGE control for the desired crowbar trip voltage. To prevent false crowbar tripping, the trip voltage should exceed the desired output voltage by the following amount: 4% of the output voltage plus 2V.
3. Slowly turn the CROWBAR ADJUST ccw until the crowbar trips, output goes to 0V or a small positive voltage.
4. The crowbar will remain activated and the output shorted until the supply is turned off. To reset the crowbar, turn the supply off, then on.
5. If the CROWBAR must be completely disabled, remove the lead attached to the CROWBAR ADJUST potentiometer R5.

A-1. Replaceable Parts

REF. DESIG.	DESCRIPTION	TQ	MFR. PART NO.	MFR. CODE	HP PART NO.	RS
C1	fxd, elect 1 μ F 50Vdc	2	30D105G050BA2	56289	0180-0108	1
C2	fxd, mica 510 μ F 500Vdc	2	RCM15E511J	04062	0140-0047	1
CR1-CR3	Diode, Si. 200mA 200prv	6		09182	1901-0033	6
CR4	SCR 7.4A 100prv	2	C20A	03508	1884-0031	2
Q1, 2	SS NPN Si.	4	2N3417	03508	1854-0087	4
R1	fxd, met. film 10 Ω \pm 1% 1/8W	2	Type CEA T-O	07716	0757-0346	1
R2	fxd, comp 6.2K Ω \pm 5% 1W	2	GB-6225	01121	0689-6225	1
R3	fxd, met. film 1.21K Ω \pm 1% 1/8W	2	Type CEA T-O	07716	0757-0274	1
R4	fxd, met. film 7.5K Ω \pm 1% 1/8W	2	Type CEA T-O	07716	0757-0440	1
R5	var. ww 10K Ω \pm 5%	2		09182	2100-1854	1
R6	fxd, ww 1K Ω \pm 5% 3W	2	242E1025	56289	0813-0001	1
R7	fxd, comp 22 Ω \pm 5% $\frac{1}{2}$ W	2	EB-2205	01121	0686-2205	1
R8	fxd, met. film 196 Ω \pm 1% 1/8W	2	Type CEA T-O	07716	0698-3340	1
T1	Transformer, Pulse	2		09182	5080-7122	1
VR1	Diode, zener 6.19V \pm 5%	2		09182	1902-0049	2
VR2	Diode, zener 2.37V \pm 5%	2		09182	1902-3002	2
MISCELLANEOUS						
	Heat Sink, CR4	2		09182	5000-6229	
	Insulator, CR4	2		09182	0340-0462	2
	Mica Washer, CR4	2		09182	2190-0709	2
	Cable Clamp	2	T4-4	79307	1400-0330	
	Bushing, Potentiometer, R5	2		09182	1410-0052	
	Nut, Hex, R5	2		09182	2950-0034	
	Label, Information, (Crowbar Adj.)	2		09182	7124-0389	
	Printed Circuit Board Assembly, Includes Components	2		09182	5060-6176	
	Modified Front Panel, Includes Components	2		09182	06255-60003	

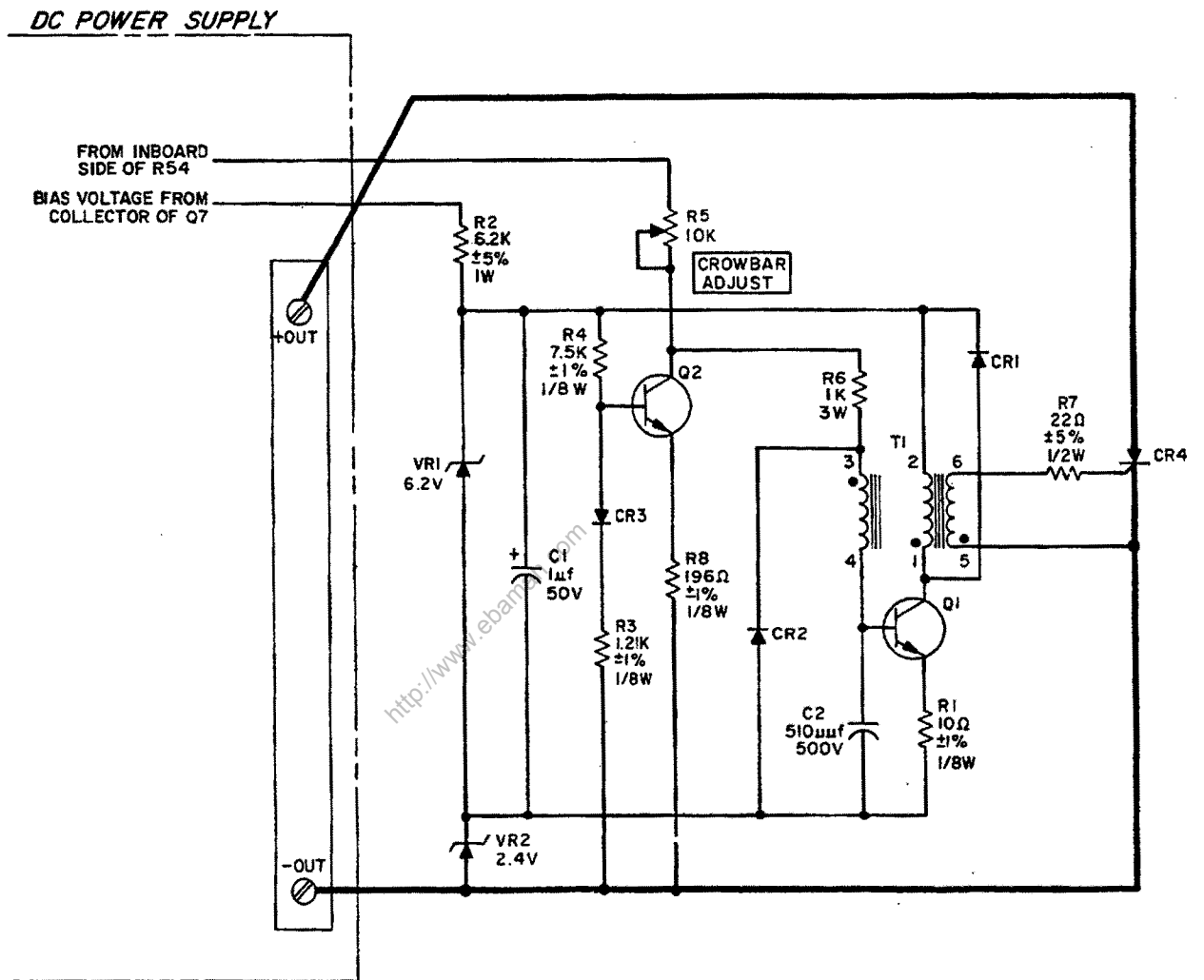

CIRCUIT PATENTS APPLIED FOR. LICENSE TO USE MUST BE OBTAINED IN WRITING FROM HEWLETT-PACKARD CO. HARRISON DIVISION.

Figure A-1. Model 6255A and 6289A Overvoltage Protection Crowbar

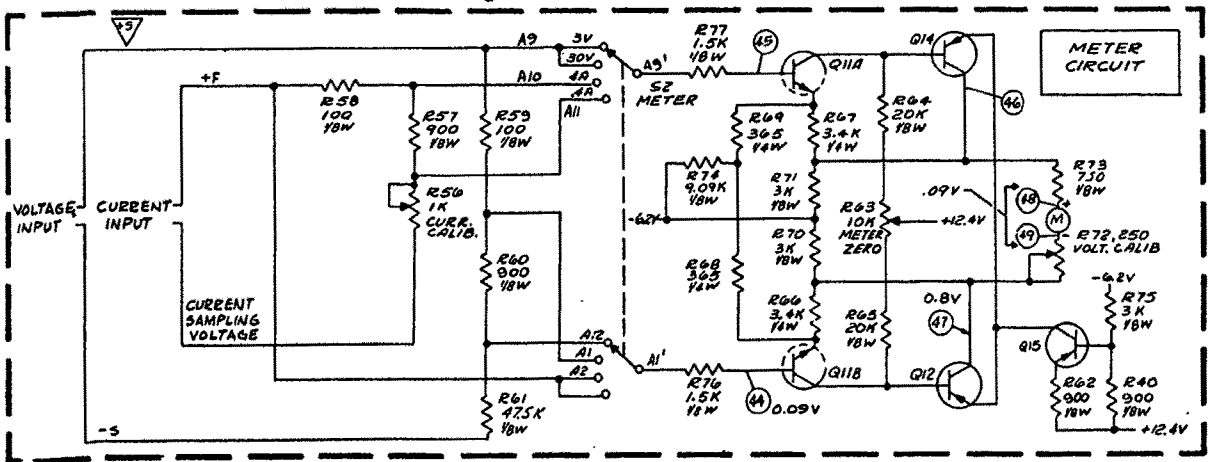
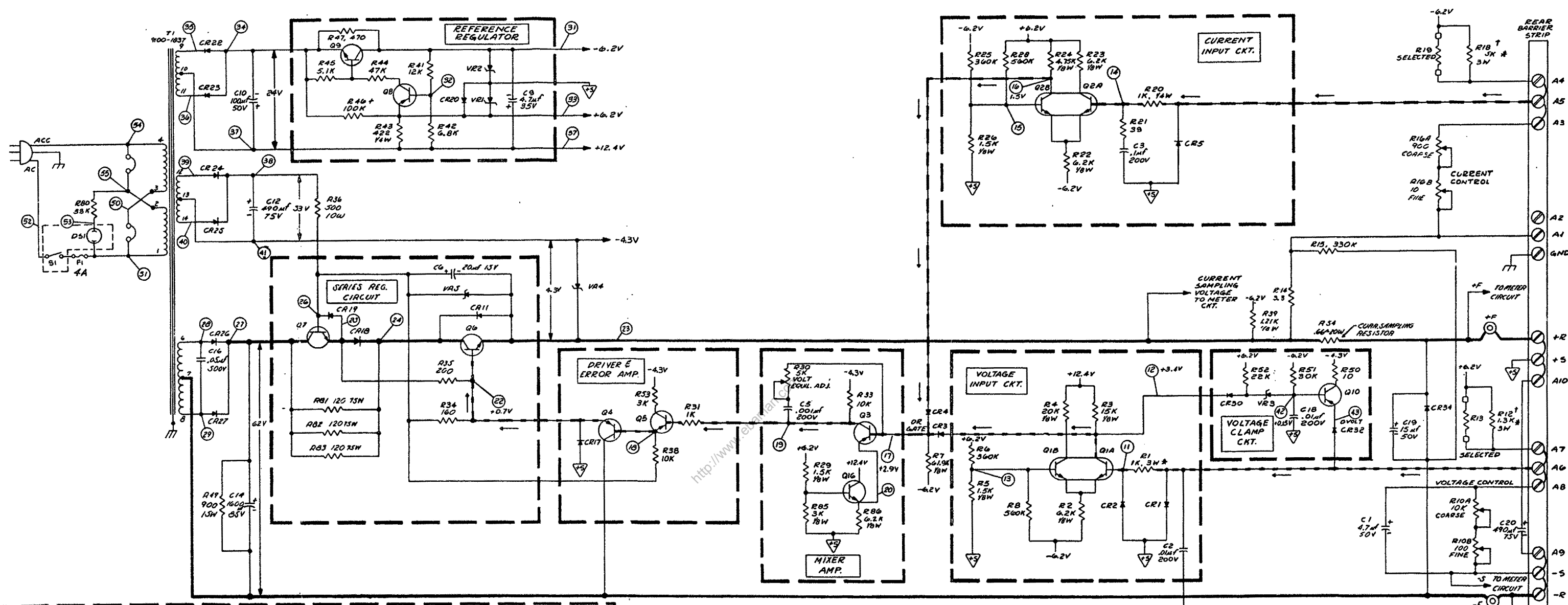

- NOTES:**
1. SCHEMATIC SHOWS (1) OF (2) IDENTICAL SUPPLIES. S1, F1 & LINE CORD ARE SHARED.
 2. ALL RESISTORS ARE 1/2 WATT ±5% UNLESS OTHERWISE NOTED.
 3. ALL 70 W AND 74 W RESISTORS ARE 1% IN TOLERANCE.
 4. * DENOTES NOMINAL VALUE COMPONENTS SELECTED FOR OPTIMUM PERFORMANCE.
 5. † DENOTES 20 PPM WIDE TEMPERATURE COEFFICIENT.
 6. REAR TERMINALS ARE SHOWN IN NORMAL STRAPPING FOR USE OF FRONT PANEL CONTROLS.
 7. ——— DENOTES VOLTAGE FEEDBACK SIGNAL.
 8. - - - - DENOTES CURRENT FEEDBACK SIGNAL.
 9. R10A & B AND R16A & B ARE BUMBLEBEE FRONT PANEL CONTROLS.
 10. TRANSFORMER SHOWN STRAPPED FOR 115 VAC OPERATION. SET INSTRUCTION MANUAL FOR 220 VAC.
 11. DC VOLTAGES WERE MEASURED UNDER THE FOLLOWING CONDITIONS:
 - A. SIMPSON MODEL 267 OR EQUIVALENT.
 - B. 115 VAC INPUT.
 - C. VOLTAGES REFERENCED TO AS UNLESS OTHERWISE NOTED.
 - D. VOLTAGES ARE TYPICAL ±10% UNLESS OTHERWISE NOTED.
 - E. ALL READINGS TAKEN IN CONSTANT VOLTAGE OPERATION AT MAXIMUM RATED OUTPUT WITH NO LOAD CONNECTED. CURRENT CONTROLS SHOULD BE TURNED FULLY COUNTERCLOCKWISE.

PATENTS APPLIED FOR ON THIS CIRCUIT. LICENSE TO USE MUST BE OBTAINED IN WRITING FROM HARRISON DIVISION OF HEWLETT-PACKARD COMPANY.

DESIGNED BY J. LILGER	DATE 4-18-67	REVISIONS	DATE
CHECKED BY J. LILGER	DATE 4-18-67	APPROVED	DATE
6255A SCHEMATIC		HEWLETT-PACKARD LABORATORY INSTRUMENTS	
G PREDRAWN - SEE OLD MASTER		J. LILGER 4-18-67	
PART NO. 6255-91001-1			



<http://www.ebaman.com>

Printed in USA

Order Part Number

06255-90002

E0667-U0788

Manufacturing Part Number

06255-90002



BACK OF FRONT PANEL

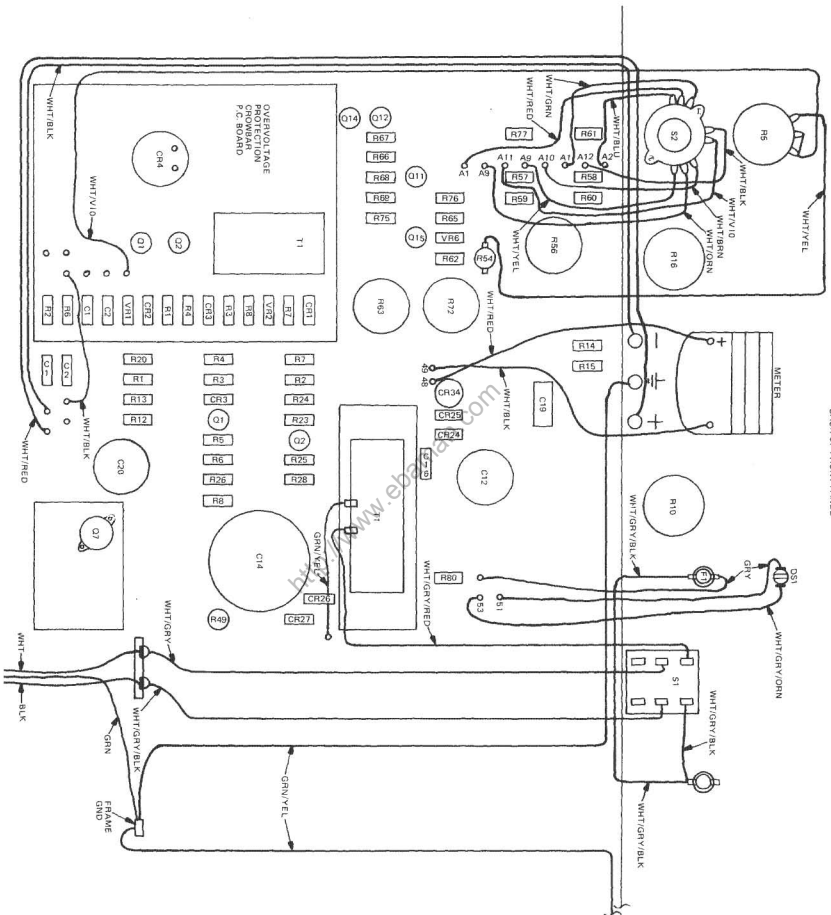

BACK OF FRONT PANEL

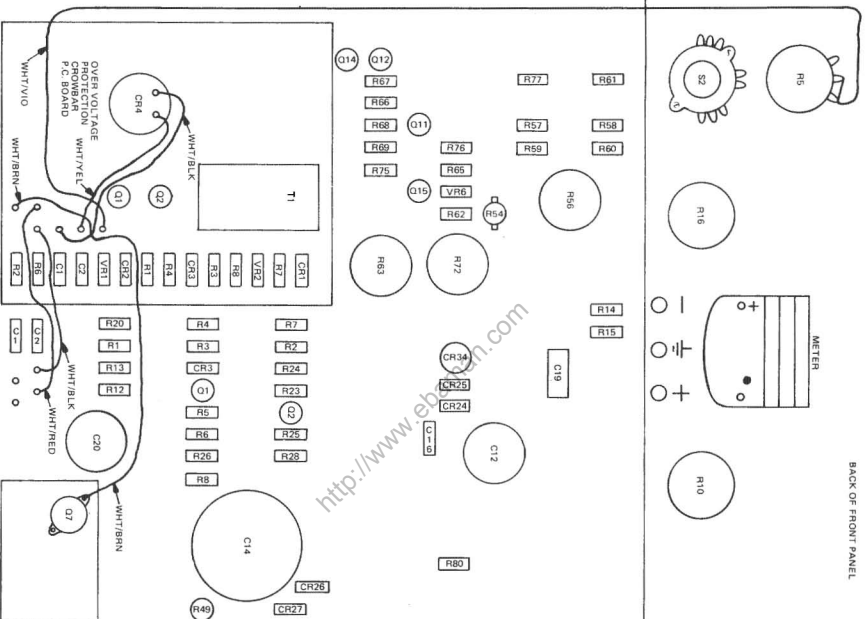

OVERVOLTAGE PROTECTION
INTERCONNECTION DIAGRAM